

**Sabre Disc Drive**

---

**ST8741J/N, ST8851J/N**

---

**ST81123J, ST81154K** DKD-502

---

**ST81236J/K/N** DKD-501

---

**Maintenance Manual**

---

**(All Interfaces)**

---

## WARNING

Do not attempt to install, operate, or repair the unit, before you read the important safety information located directly after the table of contents in this manual. Failure to follow that and other safety precautions in this manual could cause injury to yourself or others.

## WARNING

This equipment generates, uses and can radiate radio frequency energy and if not installed and used in accordance with the instructions manual, may cause interference to radio communications. It has been tested and found to comply with the limits for a Class A computing device pursuant to Subpart J of Part 15 of the FCC Rules which are designed to provide reasonable protection against such interference when operated in a commercial environment. Operation of this equipment in a residential area is likely to cause interference in which case the user, at his own expense, will be required to take whatever measures may be required to correct the interference.

If the operator or status/control panel (component assembly) is not installed in the inner drawer, it is your responsibility to provide any additional RFI shielding or grounding needed to ensure FCC Class A compliance.

## **Sabre Disc Drive**

**ST8741J (97200-736)**  
**ST8741N (97201-736)**  
**ST8851J (97200-850)**  
**ST8851K (97209-850)**  
**ST8851N (97201-850)**  
**ST81123J (97200-11G)**  
**ST81154K (97229-11G)**  
**ST81236J (97200-12G)**  
**ST81236K (97209-12G)**  
**ST81236N (97201-12G)**

## **Maintenance Manual (All Interfaces)**

**General Maintenance Information  
Trouble Analysis  
Repair and Replacement**

**Publication Number: 83325720-F**



## REVISION RECORD

REVISION	DESCRIPTION
01 (02-09-87)	Prereleased. Information in this edition is subject to change without notice.
02 (04-22-87)	Revised to move theory of operation section to publication 83325690.
A (05-29-87)	Manual released. This edition obsoletes all previous editions.
B (12-14-87)	Manual revised to document 850 MB and 1230 MB drives, IPI interface, voltage converter, technical and editorial changes. All but most basic electrical checks removed, and Repair & Replacement moved to section 3. This edition obsoletes all previous editions.
C (08-12-88)	Manual revised to document 1120 MB drives and 1230 MB SCSI drives. Technical and editorial changes. This edition obsoletes all previous editions.
D (01-23-89)	Manual revised to document 1153 MB IPI I/O two-head parallel drives and SMD I/O drives with voltage converters. Technical and editorial changes. This edition obsoletes all previous editions.
E (08-09-89)	Manual revised to add air baffle and Error Codes for SCSI High Performance drives. Technical and editorial changes. This edition obsoletes all previous editions.
F (03-29-90)	Editorial changes only.

REVISION LETTERS I, O, Q AND X ARE NOT USED.

© 1987,88,89,90  
 By Seagate Technology, Inc.  
 Technical Publications Department  
 12701 Whitewater Drive  
 Minnetonka, MN 55343

We value your comments. A Comment Sheet is provided at the back of this manual.

Printed in the United States of America

## LIST OF EFFECTIVE PAGES

This manual is at revision F. Each page in your manual should be at the revision level listed below. The "Div" is a colored divider page.

PAGE/REV	PAGE/REV	PAGE/REV	PAGE/REV	PAGE/REV					
Cover	-	1-5	B	2-17	B	2-45	E	3-11	E
Warnings	-	1-6	E	2-18	B	2-46	E	3-12	E
Title P	-	1-7	D	2-19	B	2-47	E	3-13	B
f-2	F	1-8	D	2-20	C	2-48	E	3-14	B
f-3	F	1-9	E	2-21	B	2-49	E	3-15	B
Blank	-	1-10	E	2-22	E	2-50	E	3-16	E
f-5	F	1-11	D	2-23	B	2-51	E	3-17	C
f-6	F	1-12	D	2-24	B	2-52	E	3-18	E
f-7	E	1-13	D	2-25	B	2-53	E	3-19	B
f-8	E	Blank	-	2-26	C	2-54	E	Blank	-
f-9	E	S-2 Div	-	2-27	B	2-55	E	3-21	C
Blank	-	Blank	-	2-28	D	2-56	E	3-22	B
f-11	E	2-1	E	2-29	D	2-57	E	3-23	D
f-12	E	2-2	E	2-30	E	2-58	E	3-24	E
f-13	E	2-3	B	2-31	B	2-59	E	3-25	B
f-14	E	2-4	B	2-32	B	2-60	E	3-26	E
f-15	E	2-5	B	2-33	B	S-3 Div	-	3-27	D
Blank	-	2-6	B	2-34	C	Blank	-	Blank	-
f-17	F	2-7	B	2-35	D	3-1	B	3-29	E
f-18	E	2-8	E	2-36	B	Blank	-	3-30	B
f-19	E	2-9	B	2-37	B	3-3	B	3-31	B
f-20	E	2-10	E	2-38	B	3-4	E	3-32	E
S-1 Div	-	2-11	E	2-39	D	3-5	E	3-33	D
Blank	-	2-12	E	2-40	D	Blank	-	3-34	E
1-1	B	2-13	E	2-41	D	3-7	E	Cmt Sht	-
1-2	F	2-14	B	2-42	D	3-8	E	Rtn Env	-
1-3	F	2-15	B	2-43	D	3-9	E	Blank	-
1-4	E	2-16	B	2-44	E	3-10	E	Cover	-



## PREFACE

---

This manual contains maintenance information for the Seagate PA8XX SABRE eight-inch module drive. It is prepared for customer engineers and other technical personnel directly involved with maintaining the drive.

The information in this manual is presented as follows:

- Section 1 - General Maintenance Information. Contains information on warnings and precautions, maintenance tools and materials, testing the drive, and accessing the drive for maintenance.
- Section 2 - Trouble Analysis. Contains procedures and information to assist in troubleshooting the drive.
- Section 3 - Repair and Replacement. Contains procedures and information on the replacement of drive assemblies.

New features, technical changes, additions, and deletions in this manual are indicated as follows:

- A vertical bar in the outer margin of a page marks the changed area.
- A dot by the page number indicates the entire page contains new or changed information.
- A vertical bar by the page number indicates the information was moved from another page, but there were no technical or editorial changes.

The following manuals apply to the SABRE and are available from:

Seagate Technology, Inc.  
Customer Services  
12701 Whitewater Drive  
Minnetonka, MN 55343

Phone: (612) 931-8612  
Fax: (612) 931-8817

<u>Publication No.</u>	<u>Title</u>
83325660	Reference Card (summarizes status codes and diagnostic operation for drives with the SMD and IPI interfaces)
83325690	PA8XX Theory Manual
83325700	PA8XX Parts Data Manual (contains listings of field replaceable parts, manufacturer's recommended spare parts, and accessories)
83325710	PA8G1/PA8G2/PA8K1/PA8K2/PA8N1/PA8N2/PA8W2 User's Manual (contains general description, operation, installation and checkout information)
83325720	PA8XX Maintenance Manual
83325730	PA8XX Diagrams Manual
83325810	Reference Card (summarizes status codes and diagnostic operation for drives with the SCSI interface)
83325860	PA8H1/PA8L1/PA8P1/PA8P3 User's Manual (contains general description, operation, installation and checkout information)
83326010	PA8M2/PA8R2/PA8Y2 User's Manual (contains general description, operation, installation and checkout information)
83327150	Special Supplement (applies to PA8K2D)
83327160	Special Supplement (applies to half-rack mounting kit)

For more information about the interfaces described in this manual, you can request copies of interface specifications from your Seagate sales representative. The following specifications are available:

<u>Specification No.</u>	<u>Title</u>
64712402	SMD-E Interface Specification
64721701	Interface Specification for the MPI Small Computer System Interface (SCSI)
64731600	Interface Specification for IPI-2 Intelligent Peripheral Interface

The following table lists the drives covered by this manual:

Equipment Number	Interface	Data Capacity (MB)	Sector Length
PA8G1A	Single Channel SMD	736	Unspecified
PA8G2A	Dual Channel SMD	736	Unspecified
PA8G2C*	Dual Channel SMD	736	Unspecified
PA8G2D	Dual Channel SMD	736	Unspecified
PA8H1A	STD SCSI (Differential)	736	512 Bytes
PA8H1B	STD SCSI (Single-ended)	736	512 Bytes
PA8H1C	STD SCSI (Differential)	736	256 Bytes
PA8H1D	STD SCSI (Single-ended)	736	256 Bytes
PA8H1E	STD SCSI (Differential)	736	512 Bytes
PA8K1A	Single Channel SMD	850	Unspecified
PA8K2A	Dual Channel SMD	850	Unspecified
PA8K2D	Dual Channel SMD	850	Unspecified
PA8K2E*	Dual Channel SMD	850	Unspecified
PA8K2F*	Dual Channel SMD	850	Unspecified
PA8K2H	Dual Channel SMD	850	Unspecified
PA8K2J	Dual Channel SMD	850	Unspecified
PA8L1A	STD SCSI (Differential)	850	512 Bytes
PA8L1B	STD SCSI (Single-ended)	850	512 Bytes
PA8L1C	STD SCSI (Differential)	850	256 Bytes

\* This drive has an optional voltage converter to permit operation with a power supply providing fewer output voltages than the standard supply.

Continued

Equipment Number	Interface	Data Capacity (MB)	Sector Length
PA8L1D	STD SCSI (Single-ended)	850	256 Bytes
PA8L1E	STD SCSI (Differential)	850	512 Bytes
PA8L1K	STD SCSI (Single-ended)	850	512 Bytes
PA8M2A	IPI	850	Std Format
PA8M2B	IPI	850	512 Bytes
PA8M2C	IPI	850	1024 Bytes
PA8M2D	IPI	850	Std Format
PA8N1A	Single Channel SMD	1230	Unspecified
PA8N1B	Single Channel SMD	1230	Unspecified
PA8N2A	Dual Channel SMD	1230	Unspecified
PA8N2B*	Dual Channel SMD	1230	Unspecified
PA8N2C	Dual Channel SMD	1230	Unspecified
PA8N2D	Dual Channel SMD	1230	Unspecified
PA8N2E	Dual Channel SMD	1230	Unspecified
PA8N2F	Dual Channel SMD	1230	Unspecified
PA8N2G	Dual Channel SMD	1230	Unspecified
PA8P1A	HP SCSI (Differential)	1230	512 Bytes
PA8P1B	HP SCSI (Single-ended)	1230	512 Bytes
PA8P1C	HP SCSI (Differential)	1230	256 Bytes
PA8P1D	HP SCSI (Single-ended)	1230	256 Bytes
PA8P1E	HP SCSI (Differential)	1230	512 Bytes
PA8P1F	HP SCSI (Differential)	1230	512 Bytes
PA8P1G	HP SCSI (Differential)	600	256 Bytes
PA8P1H	HP SCSI (Single-ended)	1230	512 Bytes

Continued

Equipment Number	Interface	Data Capacity (MB)	Sector Length
PA8P3A	HP SCSI (Differential)	1230	256 Bytes
PA8P3B	HP SCSI (Differential)	1230	512 Bytes
PA8P3C	HP SCSI (Differential)	1230	256 Bytes
PA8P3D	HP SCSI (Differential)	600	512 Bytes
PA8R2A	IPI	1230	Std Format
PA8R2B	IPI	1230	512 Bytes
PA8R2C	IPI	1230	1024 Bytes
PA8R2D	IPI	1230	288 Bytes
PA8R2E	IPI	1230	2308 Bytes
PA8W2A	Dual Channel SMD	1120	Unspecified
PA8W2B*	Dual Channel SMD	1120	Unspecified
PA8W2C	Dual Channel SMD	1120	Unspecified
PA8W2D	Dual Channel SMD	1120	Unspecified
PA8Y2A	IPI (2-Head Parallel)	1153	



# CONTENTS

---

Important Safety Information and Precautions	f-17
Abbreviations	f-19
1. GENERAL MAINTENANCE INFORMATION	
Introduction	1-1
Electrostatic Discharge Protection	1-1
Maintenance Tools and Materials	1-3
Testing the Drive	1-3
Field Test Units	1-3
Drive Diagnostics	1-4
System Software	1-4
Identifying Test Points	1-5
Accessing Assemblies for Maintenance	1-6
2. TROUBLE ANALYSIS	
Introduction	2-1
Drive Power On Test	2-2
Voltage Checks	2-4
Troubleshooting Procedures	2-5
TSP1 - Power Check	2-8
TSP2 - Voltage Fault Check	2-10
TSP3 - First Seek Check	2-14
TSP4 - Seek Check	2-15
TSP5 - Write Check	2-16
TSP6 - Read Check	2-18
TSP7 - Address Mark Check	2-19
Diagnostic Testing	2-20
General	2-20
Test Selection Procedure	2-22
83325720 E	f-11

Test Descriptions	2-23
Test 00 -- Display Drive Operating Status Log	2-24
Test 01 -- Display Fault Log	2-25
Test 04 -- Calculate Three Most Likely Field Replaceable Units	2-26
Test 05 -- Servo Test	2-27
Test 06 -- Clear Drive Operating Status Log	2-27
Test 07 -- Clear Fault Log	2-28
Test 08 -- Direct or Continuous Seeks	2-28
Test 09 -- Random Seek	2-29
Test 0C -- Display EPROM Part Number	2-29
Test 0E -- Return to Zero	2-29
Test 2F -- I/O Test	2-30
Drive Status Codes	2-30
Interface Testing	2-38
Testing SMD Interface Drives	2-38
Testing SCSI Interface Drives	2-39
I/O Board Self-Test	2-39
Inquiry Command	2-41
Receive Diagnostic Results Command	2-43
Additional Length Bytes	2-44
FRU Code	2-44
Error Code	2-44
Reading the I/O Board LEDs on Standard SCSI Drives	2-48
Reading the I/O Board LEDs on High-Performance SCSI Drives	2-52
Testing IPI Interface Drives	2-53
The Self-Test and Initialization Sequence	2-54
Starting the Tests	2-54
Execute Internal Diagnostics Function	2-55
Read Drive Specific Information (Bus Control 43)	2-55
3. REPAIR AND REPLACEMENT	
Introduction	3-1
3101 - Top Cover Removal & Replacement	3-4
Removal	3-4
Replacement	3-7

3102 - Entire Drive Removal & Replacement	3-8
Removal	3-8
Replacement	3-9
3103 - Front Panel Removal & Replacement	3-12
Removal	3-12
Replacement	3-14
3201 - Fan Removal & Replacement	3-16
Removal	3-16
Replacement	3-16
3202 - Operator Panel and Status/Control Panel Removal & Replacement	3-18
Removal	3-18
Replacement	3-21
3203 - Power Supply Removal & Replacement	3-22
Removal	3-22
Replacement	3-24
3204 - Module Removal & Replacement	3-25
Removal	3-25
Replacement	3-25
3301 - I/O Board Removal & Replacement	3-26
Removal	3-26
Replacement	3-29
3302 - Control Board Removal & Replacement	3-30
Removal	3-30
Replacement	3-30
3303 - Voltage Converter Removal & Replacement	3-32
Removal	3-32
Replacement	3-32

## FIGURES

1-1	Test Points	1-5
1-2	Component Locator	1-8
2-1	Example of Troubleshooting Procedure	2-7

2-2	Switches and Indicators	2-20
2-3	Example of LCD (Liquid Crystal Display)	2-31
3-1	Top Cover Removal and Replacement	3-5
3-2	Drive Removal & Replacement	3-10
3-3	Front Panel Removal & Replacement	3-13
3-4	Fan Removal and Replacement	3-17
3-5	Operator Panel or Status/Control Panel Replacement	3-19
3-6	Power Supply Removal & Replacement	3-23
3-7	Power Supply Voltage Conversion	3-24
3-8	Typical I/O Board Removal and Replacement	3-27
3-9	Control Board Removal & Replacement	3-31
3-10	Voltage Converter Removal & Replacement	3-33

## TABLES

1-1	Maintenance Tools and Materials	1-2
2-1	Power On Test Failure	2-3
2-2	DC Voltage Distribution	2-5
2-3	Switch/Indicator Descriptions	2-21
2-4	Summary of Diagnostic Tests	2-23
2-5	Coding of Field Replaceable Units	2-26
2-6	Drive Status Codes	2-31
2-7	SMD-E Online FRU Codes	2-39
2-8	Typical Inquiry Data	2-41
2-9	Diagnostic Data Return Bytes	2-43
2-10	SCSI Online FRU Codes	2-44
2-11	Standard SCSI Error Codes	2-45
2-12	High-Performance SCSI Error Codes	2-46
2-13	I/O Board Leds on High-Performance SCSI Drives	2-52
2-14	Native-Controlled Diagnostic Status Codes	2-57
2-15	Native-Controlled Diagnostic FRU Codes	2-58
2-16	Native-Controlled Diagnostic Fault Codes	2-58

2-17	Interface-Controlled Diagnostic Status Codes	2-59
2-18	Interface-Controlled Diagnostic FRU Codes	2-60
2-19	Interface-Controlled Diagnostic Fault Codes	2-60



## IMPORTANT SAFETY INFORMATION AND PRECAUTIONS

---

Use of proper safety and repair techniques is important for safe, reliable operation of this unit. Service should be done only by qualified persons. We recommend the procedures in this manual as effective ways of servicing the unit. Some procedures require the use of special tools. For proper maintenance and safety, you must use these tools as recommended.

The procedures in this manual and labels on the unit contain warnings and cautions that must be carefully read and followed to minimize or eliminate the risk of personal injury. The warnings point out conditions or practices that may endanger you or others. The cautions point out conditions or practices that may damage the unit, possibly making it unsafe for use.

You must also understand that these warnings and cautions are not exhaustive. We cannot possibly know, evaluate, and advise you of all the ways in which maintenance might be performed or the possible risk of each technique. Consequently, we have not completed any such broad evaluation. If you use a non-approved procedure or tool, first ensure that the method you choose will not risk either your safety or unit performance.

For the safety of yourself and others, observe the following warnings and precautions.

- Perform all maintenance by following the procedures in this manual.
- Follow all cautions and warnings in the procedures and on unit labels.
- Use the special tools called out in the procedures.
- Use sound safety practices when operating or repairing the unit.
- Use caution when troubleshooting a unit that has voltages present. Remove power from unit before servicing or replacing parts.
- Wear safety glasses when servicing units.
- Wear safety shoes when removing or replacing heavy parts.
- Use only designated Seagate replacement parts. Non-Seagate replacement parts can adversely affect safety in addition to degrading reliability, increasing maintenance downtime, and voiding warranty coverage.

- Use care while working with the power supply because line voltages are always present when the ac power cord is connected to a power source. Setting the power supply switch to position (⏻) disables dc power to the drive but has no effect on ac power within the supply. For complete safety, remove the ac power plug from the site power outlet.
- In case of fire or other emergency, isolate the drive from main power by removing the drive power plug from the ac outlet. In situations where pulling the plug is not possible or practical, use the system main power disconnect to isolate the drives from main power.
- When the drive is mounted in an equipment rack or cabinet, ensure that the internal temperature of the rack or cabinet will not exceed the limits defined for the drive. Where units are stacked vertically, pay special attention to the top where temperatures are usually highest.
- This drive is designed to be installed and operated in accordance with IEC380, IEC435, VDE805, VDE806.
- Follow the precautions listed under Electrostatic Discharge Protection in section 1 of this manual.
- If the power supply is placed on a bench for testing, position the supply so all ventilation holes are open, to allow proper air flow to internal components.
- Do not attempt to disassemble the module. It is not field repairable. Replace the entire module assembly if it is defective.
- Do not operate the drive over an extended period of time without the top cover installed.
- If the power supply is connected to an IT network, ensure that the input voltage is limited to 230 volts.
- Do not attempt to disassemble the power supply. It is not field repairable. Replace the entire supply if it is defective.
- Always deenergize drive before removing or installing circuit boards, cables, or any other electrical components.
- If you do not use a recommended Imprimis power supply, ensure that the supply meets the specifications in this manual and is designed to be used in accordance with IEC380, IEC435, VDE805, VDE806.

## ABBREVIATIONS

---

ABV	Above	EPROM	Eraseable Programmable Read Only Memory
ac	Alternating Current		
ALT	Alternate	ESP	Enhanced SCSI Protocol
BIB	Bus In Bit	EXEC	Execute
BLW	Below	EXT	External
BOB	Bus Out Bit	FCO	Field Change Order
C	Celsius, Continuous	FRU	Field Replaceable Unit
CDIC	Controller/Drive Interface Chip	FTU	Field Test Unit
CH	Channel	GND	Ground
cm	Centimetre	HEX	Hexagon, Hexadecimal
CONTD	Continued	HP	High Performance
CYL	Cylinder	Hz	Hertz
D	Direct	IBP	Inhibit Block Pulse
dc	Direct Current	IC	Integrated Circuit
DIAG	Diagnostic	ID	Identification
DMA	Direct Memory Access	IDENT	Identification
ECC	Error Correction Code	INT	Internal
ECL	Emitter Coupled Logic	I/O	Input/Output
ECO	Engineering Change Order	IPI	Intelligent Peripheral Interface
EMD	Eight-Inch Module Drive	LCD	Liquid Crystal Display
		LED	Light Emitting Diode

## ABBREVIATIONS (Contd)

---

LSB	Least Significant Bit	RTZ	Return to Zero
LSI	Large Scale Integration	R/W	Read/Write
LTD	Lock to Data	s	Second
LUN	Logical Unit Number	SBC	SCSI Bus Controller
MAC	Merged Architecture Controller	S/C	Series Code
MB	Megabyte	SCSI	Small Computer Systems Interface
MHz	Megahertz	SEL	Select
MPU	Microprocessor Unit	STD	Standard
MSB	Most Significant Bit	SYNC	Synchronization
NRZ	Non Return to Zero	TP	Test Point
ns	Nanosecond	TSP	Troubleshooting Procedure
P	Plug	TTL	Transistor-Transistor Logic
PFTU	Programmable Field Test Unit	V	Volts, Voltage
PROC	Procedure	W/	With
RAM	Random Access Memory	W/O	Without
REF	Reference	WRT	Write
REV	Reverse, Revision	ZHP	Two-Head Parallel
RST	Reset		

**SECTION 1**

**GENERAL MAINTENANCE INFORMATION**



---

## INTRODUCTION

This section contains general information relating to maintenance of the drive. You should be familiar with the information in this section and with drive operation before attempting any maintenance procedures. Information is divided into the following areas:

- Electrostatic Discharge Protection -- Provides instructions for the proper handling of electrostatically sensitive devices.
- Maintenance Tools and Materials -- Lists the tools and materials required to perform maintenance on the drive.
- Testing the Drive -- Provides information concerning the electrical testing of the drive.
- Accessing Assemblies for Maintenance -- Identifies the various parts of the drive and describes how to access these parts for maintenance.

## ELECTROSTATIC DISCHARGE PROTECTION

All drive electronic assemblies are sensitive to static electricity, due to the electrostatically sensitive devices used within the drive circuitry. Although some of these devices such as metal-oxide semiconductors are extremely sensitive, all semiconductors as well as some resistors and capacitors may be damaged or degraded by exposure to static electricity.

Electrostatic damage to electronic devices may be caused by a direct discharge of a charged conductor, or by exposure to the static fields that surround charged objects. To avoid damage to drive electronic assemblies, service personnel must observe the following precautions when servicing the drive:

- Remove boards from bags only when you are grounded -- all boards received from the factory are in static shielding bags, and should not be removed unless you are grounded.
- Turn off power to drive before removing or installing any circuit boards.

- Ground yourself to the drive -- whenever the drive electronics are or will be exposed, connect yourself to ground with a wrist strap (see Accessories in the parts data manual). Connection may be made to any metal assembly on the drive. As a general rule, remember that you, the drive, and the circuit boards must all be at ground potential to avoid potentially damaging static discharges.
- Keep boards in conductive bags -- when circuit boards are not installed in the drive, keep them in conductive static shielding bags (see Accessories in the parts data manual). These bags provide absolute protection from direct static discharge and from static fields surrounding charged objects. Remember that these bags are conductive and should not be placed where they might cause an electrical short circuit.

TABLE 1-1. MAINTENANCE TOOLS AND MATERIALS

Description	Seagate Part Number
Portable Status/Control Panel Kit	47097271
Programmable Field Test Unit (PFTU)* (TB2A3-G with SMD-0/SMD-E option)	73086308
Small Computer System Interface (SCSI) Testers (Options for PFTU listed above) Single-Ended Kit** Differential Kit**	86515700 86515800
Static Shielding Bags and Ground Wrist Straps	See Accessories in the parts data manual
Volt/ohmmeter	Ballantine 345 or equivalent digital voltmeter
<p>*No field test unit is currently available for drives with the IPI interface. **Kit part numbers do not include the basic PFTU. The PFTU part number is listed above.</p>	

- Never use an ohmmeter on any circuit boards unless directed to in troubleshooting procedures.
- Do not touch pins on power supply connector J15. Power supply circuitry is sensitive to electrostatic discharge.

## MAINTENANCE TOOLS AND MATERIALS

The maintenance procedures described in this manual require the use of certain special tools, test equipment, and materials. These are listed in table 1-1 along with the appropriate Seagate part number. Note that the list includes only special tools. We assume that you have normal maintenance tools.

How to use the items listed in table 1-1 is described in the procedures as they are required. Additional information is provided on the optional status/control panel (see section 2, Trouble Analysis) and the field test unit (see Testing the Drive).

## TESTING THE DRIVE

During testing and troubleshooting, the drive is normally required to perform various operations such as reading and writing test data. Either a field test unit or system software can be used to control the drive during these operations.

## FIELD TEST UNITS

The TB2A3-G programmable field test unit (PFTU) is recommended for use with SMD and SCSI interface drives (see table 1-1 for tester part numbers). Testers are not currently available for drives with an IPI interface. The tester allows the drive to be operated and controlled independent of the rest of the system. For specific instructions on operating the tester, see the tester manual.

The following procedure describes how to connect the tester I/O cables to an SMD interface drive in place of the system I/O cables. For instructions on connecting a tester to a SCSI interface drive, refer to the manual provided with the SCSI tester.

## CAUTION

To avoid possible damage to interface circuitry, always deenergize drive, controller, and tester before removing or installing I/O cables.

1. Disable controller and set power supply On/Standby switch to Standby position. In a daisy chain system, power off all drives.
2. When drive is powered off, remove system I/O cables from drive to be tested.
3. Connect tester A cable to drive connector 1J03.
4. Connect tester B cable to drive connector 1J02.
5. Connect a terminator to drive connector 1J04.

See the accessories table in the parts data manual for the terminator and its part number. In a daisy chain system, make whatever connections are necessary to ensure that the other drives remain under system control, and restore power to the other drives.

At the completion of testing, restore the drive to normal operation by reversing the process outlined above.

## DRIVE DIAGNOSTICS

The drive has built-in diagnostic tests. These diagnostic tests may be performed via the optional status/control panel, located behind the drive front panel insert. See section 2 (Trouble Analysis) for operating instructions.

## SYSTEM SOFTWARE

The drive may also be tested by use of system diagnostic test programs. This requires use of the controller and the appropriate software. In this type of testing, the drive communicates with the controller as in normal online operations, and special I/O connections are unnecessary.

Refer to manuals or other documentation applicable to the specific system or subsystem for information concerning the system software routines.

## IDENTIFYING TEST POINTS

The drive circuit boards have test points to aid in signal tracing during maintenance and troubleshooting. These test points appear physically as shown on figure 1-1 and may be located anywhere on the component side of the circuit boards.

The diagrams and maintenance procedures identify a test point by referring to a connector. J80-1 is an example of a test point reference, where J80 is the connector and 1 is the pin number. TP-G620 is an example of a test point, where G620 is the coordinate locator. Where there is no test point, a board coordinate is used to locate a chip or other component. The introduction in the diagrams manual explains how to use the coordinate locators. The connector designators are letters, silkscreened onto the board. The coordinate locators progress in alphabetical order from left to right and top to bottom.

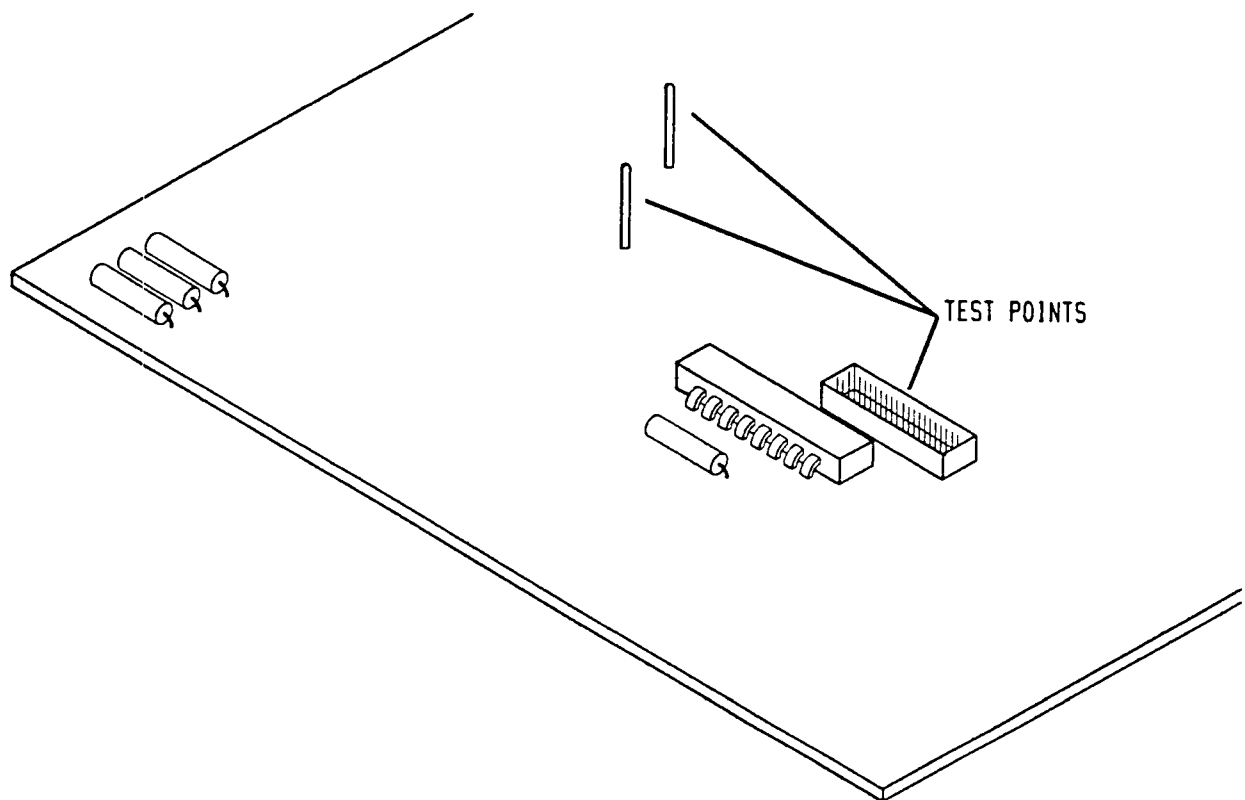

11F60

Figure 1-1. Test Points

## ACCESSING ASSEMBLIES FOR MAINTENANCE

The major drive assemblies and components are shown on figure 1-2. These parts are accessed by extending the 2X drawer on its slides, sliding the drive outward, and removing the drive top cover.

When extending the 2X drawer and drive, be careful that the equipment rack remains stable. Also, take care that the system cabling is not damaged when sliding the drive in the drawer and the drawer in and out of the rack. When removing the top cover, be careful not to damage the logic boards.

If it is necessary to remove the drive from the drawer, see the entire drive removal procedure in section 3 of this manual. Section 3 also contains a top cover removal procedure and procedures for removing most of the other field-replaceable parts, including the circuit boards.

As shown on figure 1-2, the control board is located below the top cover. The following control boards are used:

- \_XFX on 736 MB drives (standard read/write)
- \_XNX on 850 MB drives (standard read/write)
- \_XMX on 1120 MB drives (standard read/write)
- GYBX on 1153 MB drives (parallel read/write)
- AXYY on 1230 MB drives (standard read/write).

The I/O board is located behind the rear cover. The following I/O boards are used:

- \_VRX on SMD interface drives
- \_XJX on standard SCSI interface drives (differential)
- \_XLX on standard SCSI interface drives (single-ended)
- NYBX on high-performance SCSI interface drives (differential and single-ended)
- BXDX on IPI interface drives (standard read/write)
- LYBX on IPI interface drives (parallel read/write)

The arm matrix board is located within the module and cannot be serviced. Drives with standard read/write use the \_WWX board. Drives with parallel read/write use the HYBX board.

The power supply (see figure 1-2) can be attached to the inner drawer (directly in front of the drive) or mounted in a remote location, provided clearance for proper air flow is available.

When the power supply is mounted in the 2X drawer (in line with the drive), drive cooling is provided by the fan in the power supply. When the power supply is mounted in a remote location, adequate ventilation must be provided for the drive. One option for this is a fan and bracket assembly that mounts to the I/O board. Other cooling methods are acceptable as long as they satisfy the requirements specified for the drive.

Some drives contain an optional voltage converter that develops a -5 V output from the -12 V input. This option uses a special fan bracket mounted over the I/O board. The fan bracket supports a cooling fan, a BXSX voltage converter assembly, and an EWTX connector adapter board. The connector adapter board plugs into control board connector J15(B).

The operator panel and status/control panel are options that mount to the front panel. With either panel, the operator switches and indicators are accessible through an opening in the front panel insert. The status/control panel has a maintenance keyboard and display in addition to the switches and indicators found on the simpler operator panel. These unique features of the status/control panel are accessed by removing the front panel insert.

# Accessing Assemblies for Maintenance

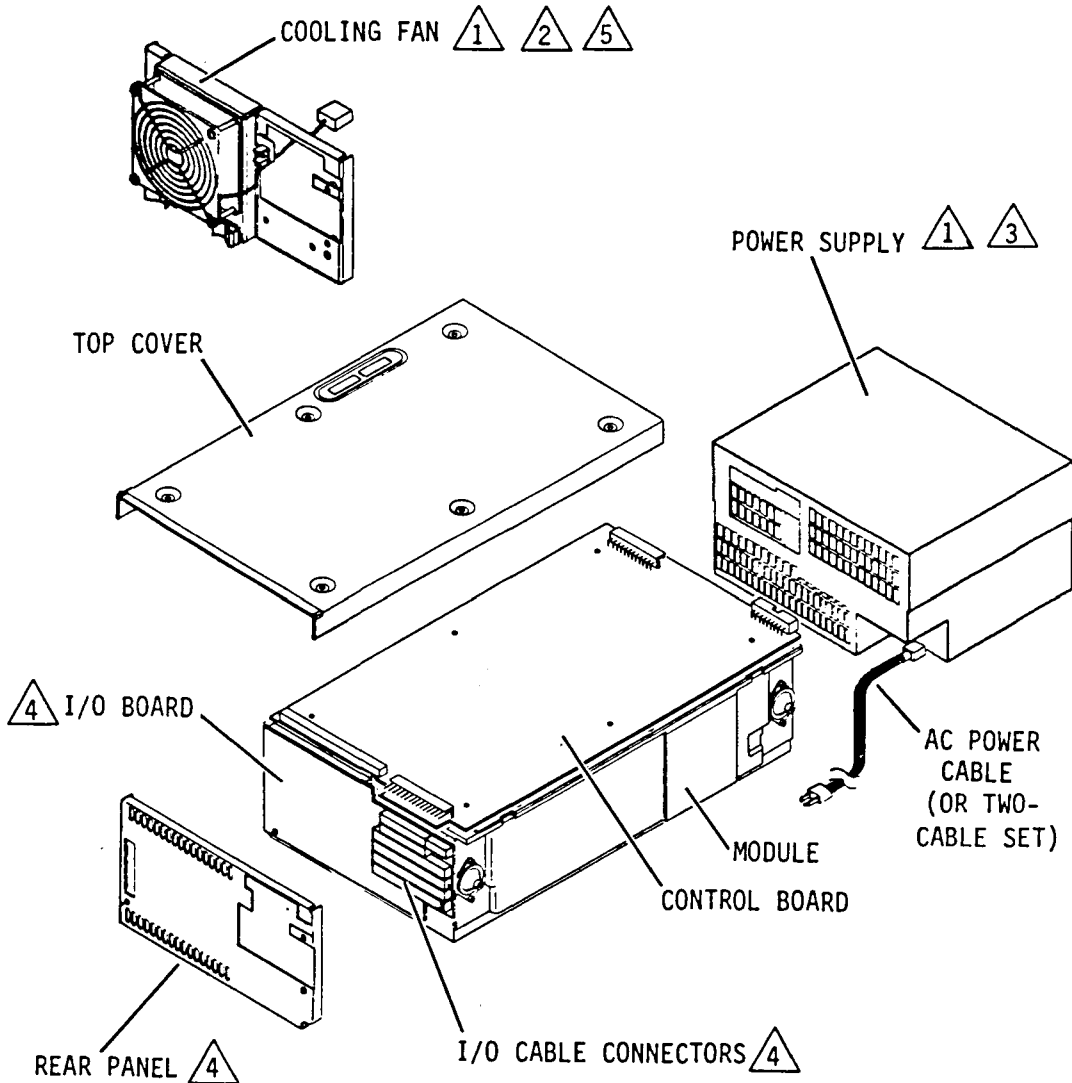

## NOTES:

- 1 OPTIONAL.
- 2 MOUNTS TO I/O BOARD. USED WHEN POWER SUPPLY IS MOUNTED IN REMOTE LOCATION.
- 3 MOUNTED DIRECTLY IN FRONT OF DRIVE OR MOUNTED IN REMOTE LOCATION.
- 4 APPEARANCE VARIES DEPENDING ON TYPE OF I/O.
- 5 SOME PANELS CONTAINING COOLING FAN ALSO CONTAIN AN OPTIONAL VOLTAGE CONVERTER. VOLTAGE CONVERTER IS NOT REQUIRED WITH POWER SUPPLY SHOWN.

11H35D

Figure 1-2. Component Locator (Sheet 1 of 6)

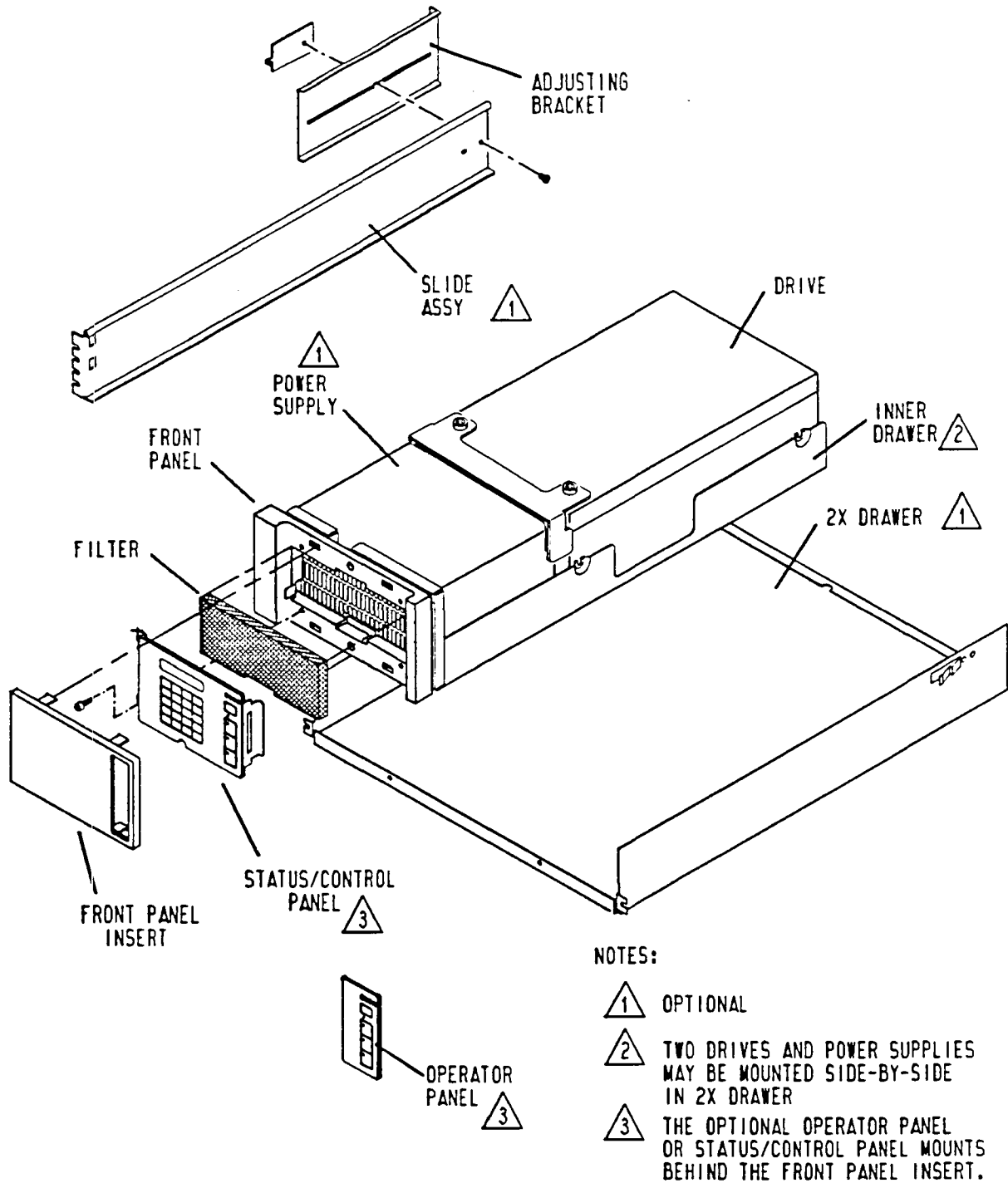

11H71A

Figure 1-2. Component Locator (Sheet 2)

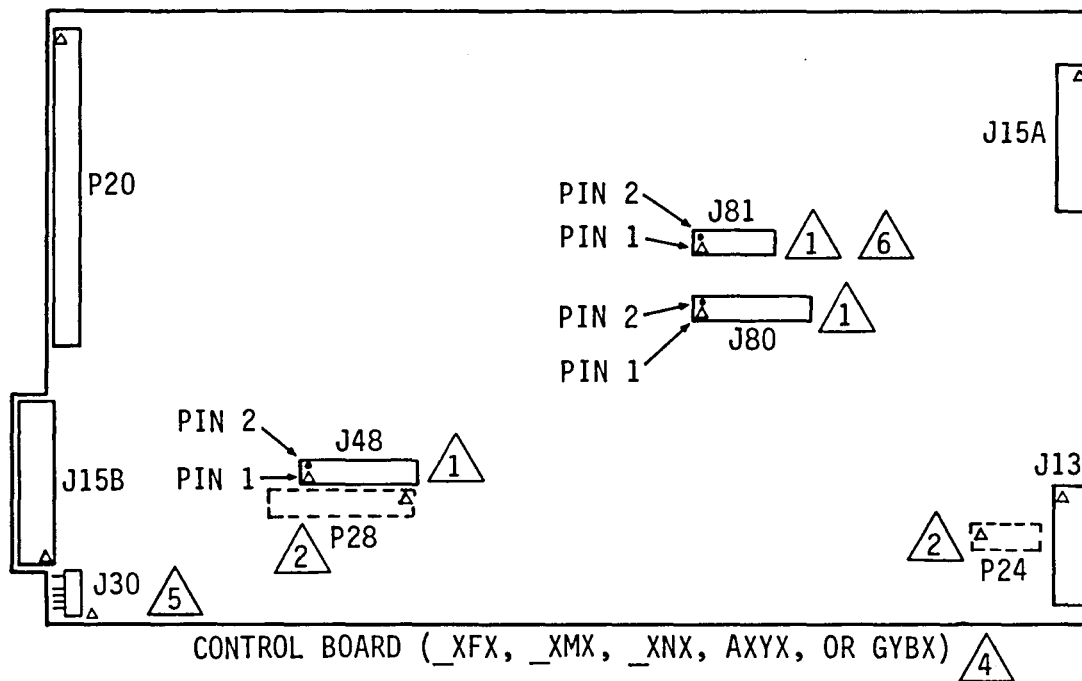

NOTES:

- 1 TEST POINTS
- 2 CONNECTS TO MODULE
- 3. Δ = LOCATION OF PIN 1
- 4 736 MB DRIVE USES \_XFX CONTROL BOARD  
850 MB DRIVE USES \_XNX CONTROL BOARD  
1120 MB DRIVE USES \_XMX CONTROL BOARD  
1153 MB DRIVE USES GYBX CONTROL BOARD  
1230 MB DRIVE USES AXYX CONTROL BOARD
- 5 ON \_XMX AND \_XYX CONTROL BOARDS ONLY
- 6 J81 NOT PRESENT ON ALL BOARDS

11H360

Figure 1-2. Component Locator (Sheet 3)

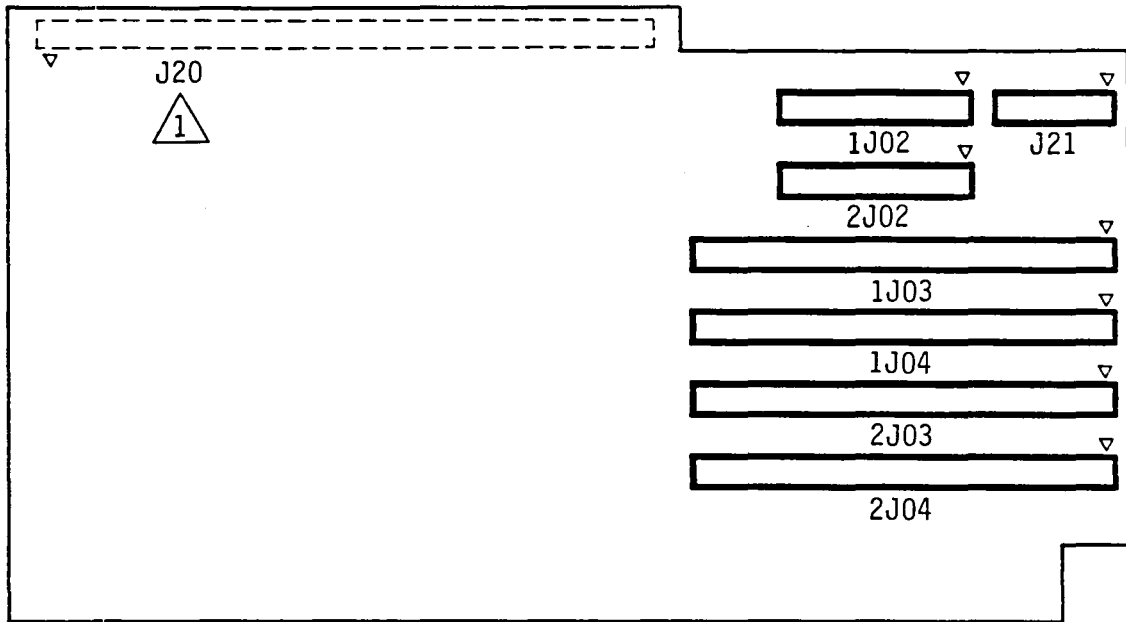

SMD I/O BOARD (\_VRX)

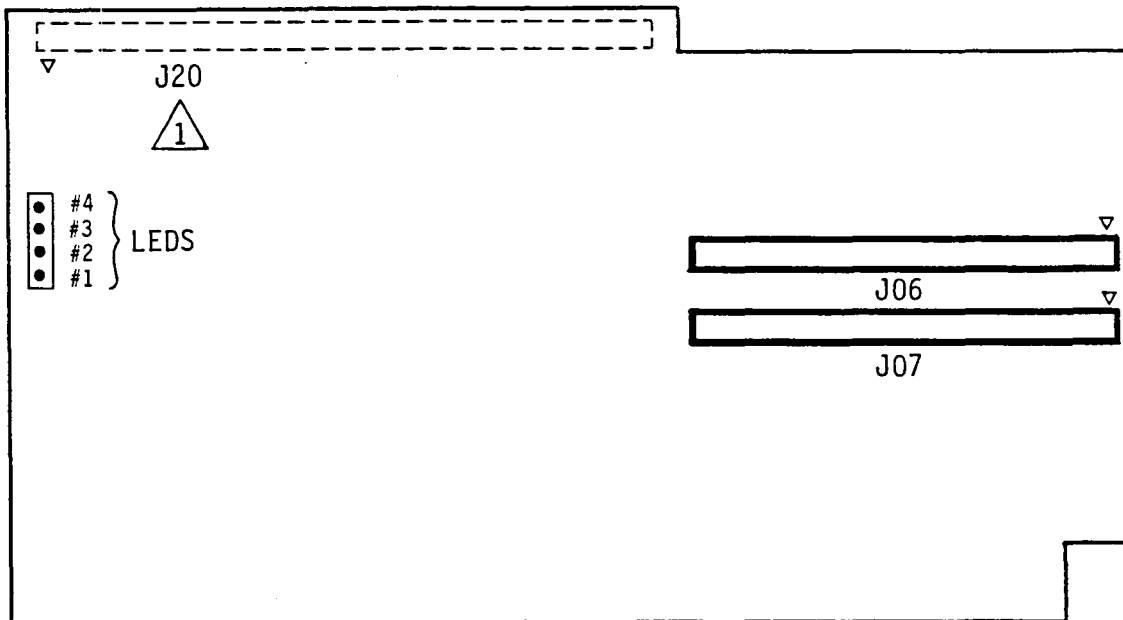

SCSI I/O BOARDS (\_XJX : DIFFERENTIAL STANDARD SCSI)

(\_XLX : SINGLE-ENDED STANDARD SCSI)

(NYBX : DIFFERENTIAL HIGH-PERFORMANCE SCSI)

(NYBX : SINGLE-ENDED HIGH-PERFORMANCE SCSI)

NOTES:

1. CONNECTS TO CONTROL BOARD

2. = LOCATION OF PIN 1

11H86C

Figure 1-2. Component Locator (Sheet 4)

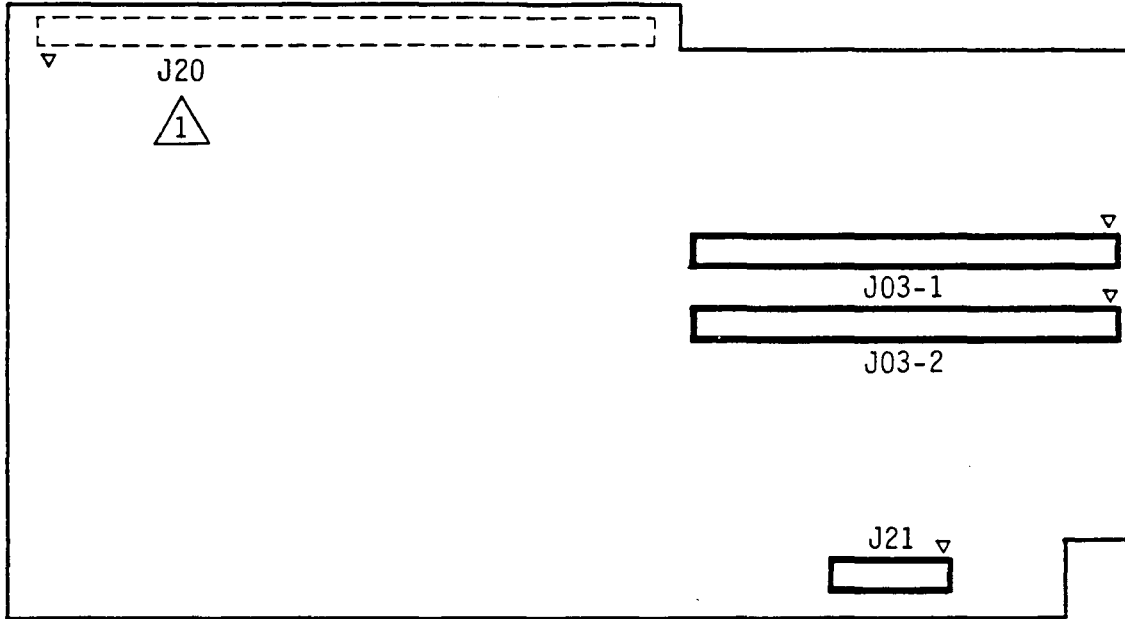

IPI I/O BOARD WITH STANDARD R/W (BXDX)

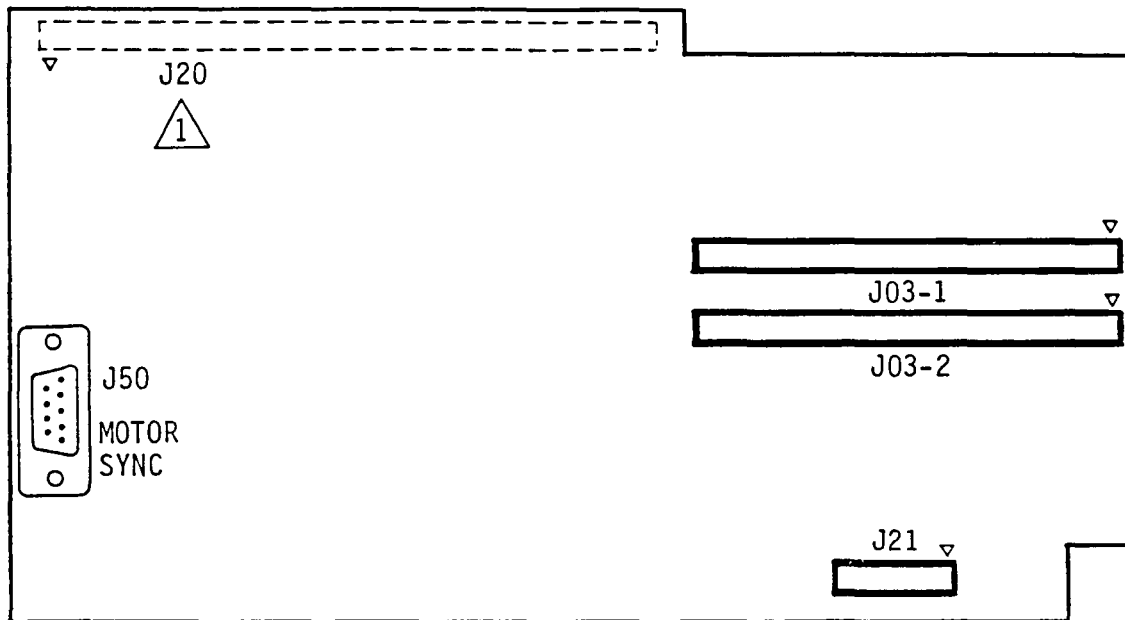

IPI I/O BOARD WITH PARALLEL R/W (LYBX)

NOTES:

1.  CONNECTS TO CONTROL BOARD

2.  = LOCATION OF PIN 1

11H158

Figure 1-2. Component Locator (Sheet 5)

STATUS/CONTROL PANEL  
(OPTIONAL)

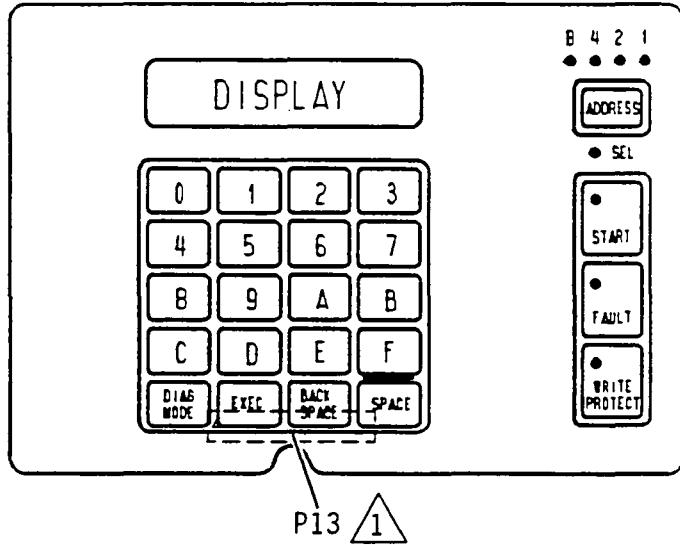

OPERATOR PANEL  
(OPTIONAL)

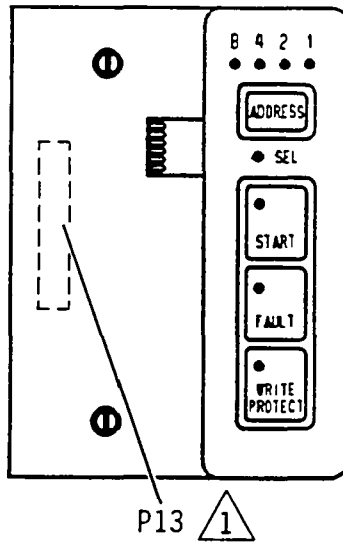

NOTES:



CONNECTS TO CONTROL BOARD



MOUNTS TO INNER DRAWER OR REMOTE LOCATION

11H87

Figure 1-2. Component Locator (Sheet 6)



**SECTION 2**

**TROUBLE ANALYSIS**



---

### CAUTION

When servicing the drive, observe all precautions listed under Electrostatic Discharge Protection in section 1 of this manual. Failure to observe these precautions can result in serious damage to electronic assemblies.

### INTRODUCTION

The trouble analysis section contains information on isolating and correcting problems causing improper drive operation. Prior to performing troubleshooting, you should be thoroughly familiar with drive operation, with all information in section 1, and with the safety information in the front of this manual.

Because of the many types of malfunctions that may occur, the information in this section will not provide a solution to every problem. The intention, therefore, is to solve common problems and to provide a starting point for the rest. The final recommendation in all cases is to call field support.

For trouble analysis, a status/control panel is needed. If the drive installation does not include a status/control panel, we advise that you connect one to the drive during troubleshooting.

When using the status/control panel for trouble analysis on drives with the IPI interface, disable the I/O by setting the port disable switches (DA - DB) on the I/O board to the On (Closed) position. Failure to disable the I/O may prevent completion of diagnostics initiated on the status/control panel, and the LCD may go blank if the controller selects the drive.

To avoid possible system problems on drives with the SCSI interface, ensure that there is no activity on the SCSI bus before proceeding with offline diagnostics.

Trouble analysis information is divided into the following parts:

- Drive Power On Test -- describes drive self-tests that occur when dc power is applied to the drive and lists what corrective actions to take if a test failure occurs.

## Introduction

- Voltage Checks -- describes how to measure dc voltages supplied to the drive.
- Troubleshooting Procedures -- describes how to isolate and correct common drive problems. The procedures cover all the major areas of drive operation: power, servo, read and write.
- Diagnostic Testing -- describes how to use offline diagnostic testing to isolate drive malfunctions.
- Drive Status Codes -- provides information on correcting problems associated with drive power-up/power-down and with servo operations.
- Interface Testing -- describes self-tests by the I/O MPU (SCSI and IPI drives) and online diagnostics (all drives).

Many of the corrective actions in this section refer to procedures given in section 3, Repair and Replacement. All procedures are referred to by number. For example, a reference to procedure 3302 refers to 3302 - Control Board Removal & Replacement in section 3. The first digit (3) always indicates the section where the procedure is found.

## DRIVE POWER ON TEST

When dc power is applied to the drive, the Control MPU performs a series of self-tests. During these tests the Address, Ready, FAULT, and WRITE PROTECT lights on the operator panel or status/control panel will be lit. After approximately four seconds, the FAULT light will go off, indicating successful completion of the self-tests. If the Ready and FAULT lights remain on constantly, it indicates the drive failed the power on self-test. The Address lights will then indicate which self-test routine the drive failed to complete. Refer to table 2-1 to determine which test failed and what action to take.

In addition to the individual tests listed in table 2-1, the Control MPU attempts to communicate with the status/control panel. If this communication is unsuccessful, the Control MPU displays the message PANEL FAILURE on the LCD of the panel.

On drives with a SCSI or IPI interface, the I/O MPU begins a series of self-tests while the drive self-tests are running. Refer to Interface Testing at the end of this section for more information.

TABLE 2-1. POWER ON TEST FAILURE

Address Lights*	Hex Code	Test Failed** & Actions
8    4    2    1		
●   ●   ●   ●	F	<u>RAM Test</u>
		Action: 1. Replace control board.
●   ●   ●   ○	E	<u>ROM Test</u>
		Action: 1. Replace control board.
●   ●   ○   ●	D	<u>I/O Chip Test</u>
		Actions: 1. Replace I/O board. 2. Replace control board.
●   ●   ○   ○	C	<u>Peripheral Chip (Test 1)</u>
		Action: 1. Replace control board.
●   ○   ●   ●	B	<u>Peripheral Chip (Test 2)</u>
		Action: 1. Replace control board.
●   ○   ●   ○	A	<u>Motor MPU Test</u>
		Action: 1. Replace control board.

\* Darkened circles indicate light is On.

\*\*Ready and FAULT lights remain on constantly, indicating drive failed four second power on self test.

## VOLTAGE CHECKS

The following procedure provides an overall check of the dc voltages used by the drive. Table 2-2 shows the voltages required by each drive component. See the diagrams manual for specific information concerning voltage test points.

Prior to performing this procedure you should be thoroughly familiar with drive operation, with all information in section 1, and with the safety information in the front of this manual. Refer to figure 1-2 (component locator) for pin orientation of connectors J80 and J15 on the control board.

### CAUTION

Because some voltage measurements are on pins adjacent to each other, it is possible to touch both pins simultaneously, thus causing a short circuit. A short circuit will cause serious damage to drive electronic assemblies. Therefore, use extreme caution when performing the following steps.

1. Command continuous seeks between cylinder 0 and 256.
2. Connect voltmeter ground lead to J80-9 (chassis ground).
3. Measure between ground and the appropriate connection points to check the following voltages:

<u>Voltage</u>	<u>Connection</u>	<u>Specification</u>
+5 volts	J80-20	+4.85 to +5.25 volts
-5 volts	J80-22	-4.90 to -5.30 volts
-12 volts	J80-23	-11.4 to -12.6 volts
+24 volts	J15-12	+22.8 to +25.2 volts
+12 volts	J80-21	+11.80 to +12.20 volts
Ground	J80-9	

TABLE 2-2. DC VOLTAGE DISTRIBUTION

Component	Voltage				
	+5 V	-5 V	-12 V	+12 V	+24 V
Control Board	X	X	X	X	X
I/O Board	X	X			
Status/Control Panel	X	X		X	
Operator Panel	X	X		X	
Fan					X

## TROUBLESHOOTING PROCEDURES

The troubleshooting procedures describe how to isolate and correct common drive problems. Figure 2-1 is an example of a troubleshooting procedure and explains the format. The following paragraphs explain how to use the troubleshooting procedures.

Before starting a procedure, ensure that all assumptions have been satisfied. The assumptions along with other advisory information are given in the introductory paragraph to the procedure and describe conditions that must exist for the procedure to be valid.

When the assumptions are satisfied, proceed to the first step of the procedure. After performing the action or answering the question, follow the line down to the next step. For a question, follow the line beneath the appropriate Y (yes) or N (no) response. Continue until a corrective action is reached.

After taking the first recommended action, retest the unit. If the test results do not change, try recommended action 2, and so on, being sure to retest after each action. The corrective actions which are easier to perform (checking a signal or changing a circuit board, for example) are listed before the more difficult tasks such as replacing the module. If the corrective actions do not solve the problem, call field support.

The procedures appear in the following order:

- TSP1 - Power Check: Isolates problems in the drive related to short circuits.
- TSP2 - Voltage Fault Check: Isolates problems in the drive related to dc power failures.
- TSP3 - First Seek Check: Provides possible causes for the drive failing to successfully complete a first seek.
- TSP4 - Seek Check: Provides possible causes for the drive failing to successfully complete a seek.
- TSP5 - Write Check: Provides information for isolating cause of write errors.
- TSP6 - Read Check: Provides information for isolating cause of read errors.
- TSP7 - Address Mark Check: Provides possible causes for read or write address mark problems.

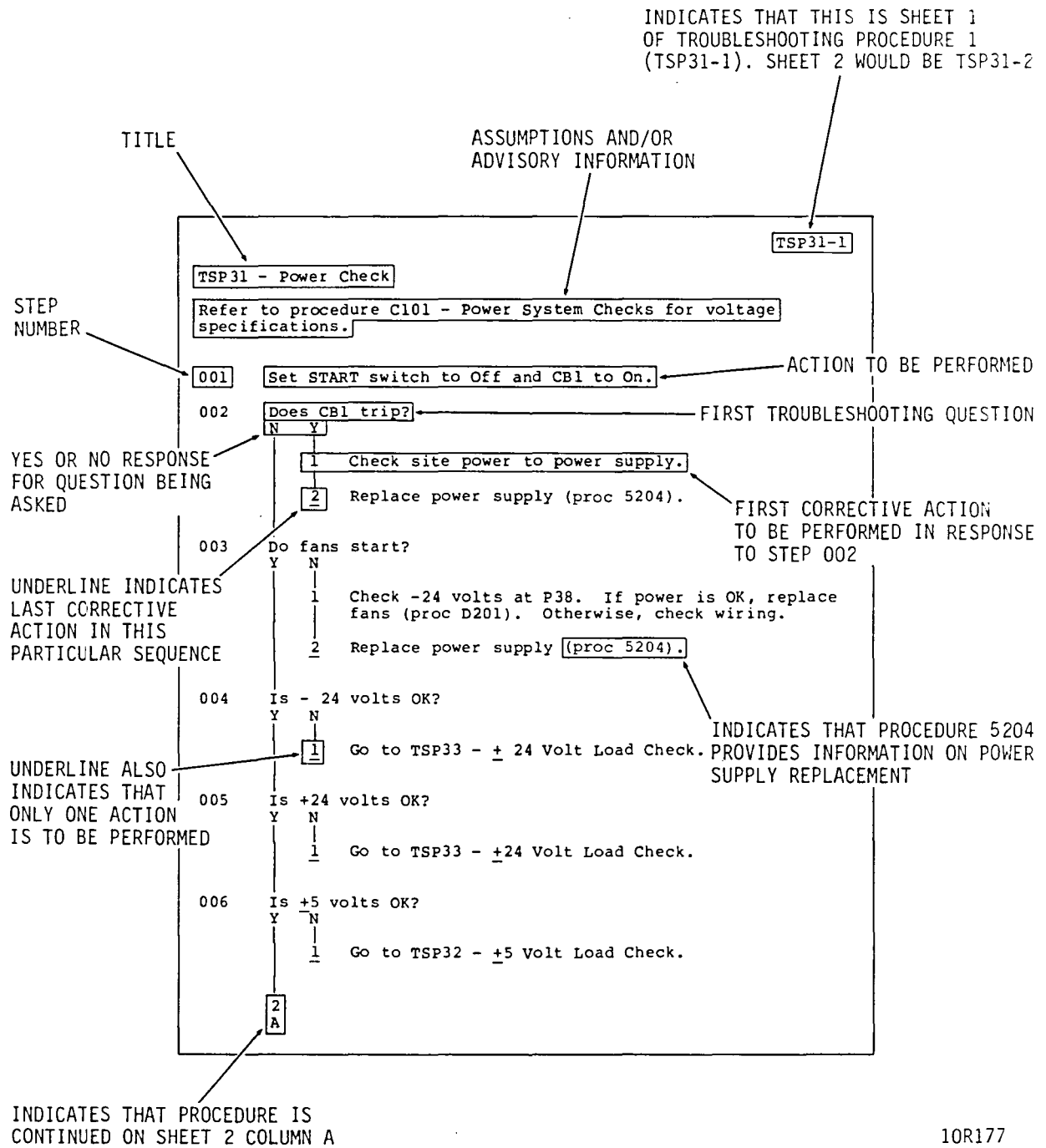
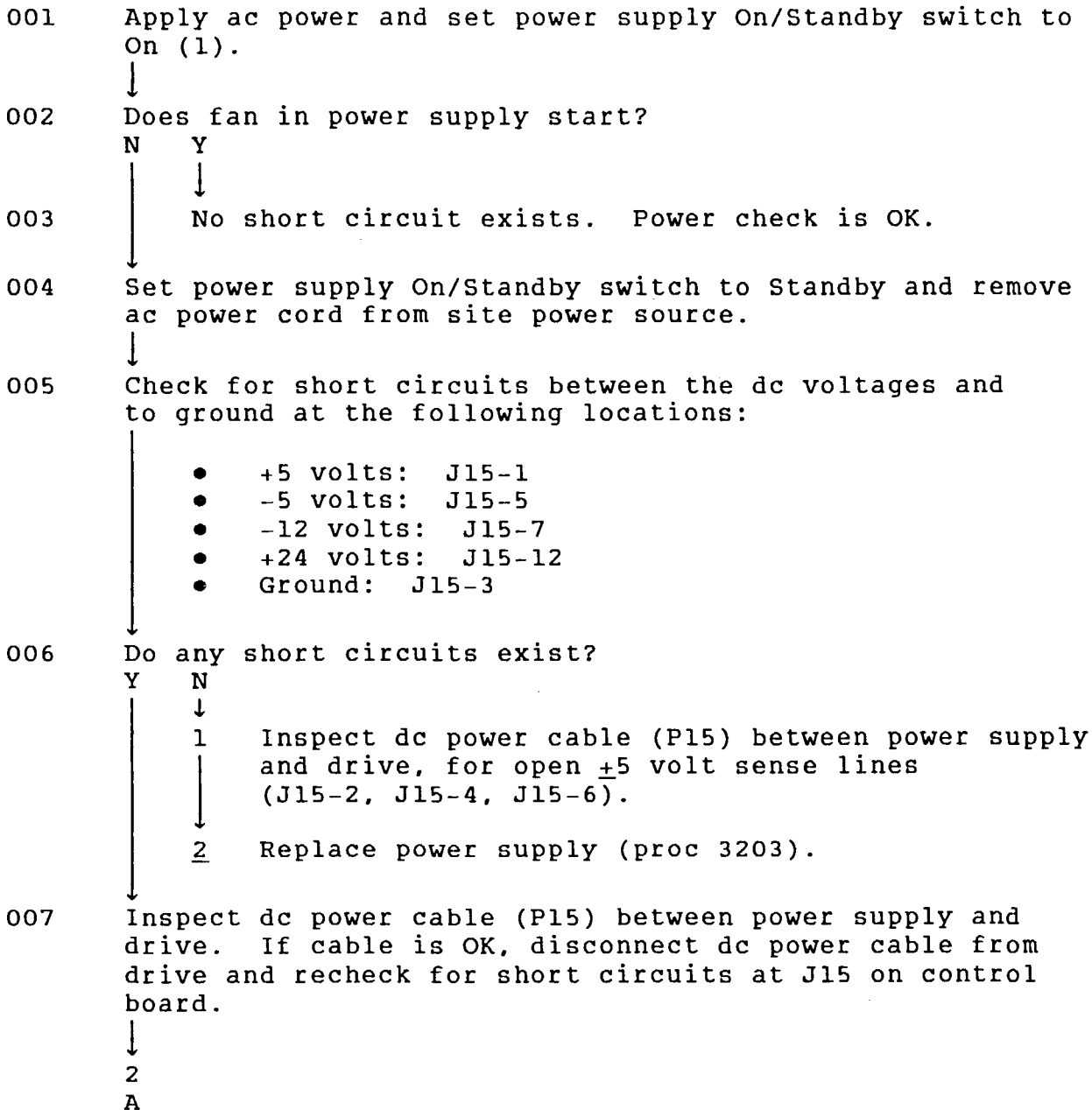
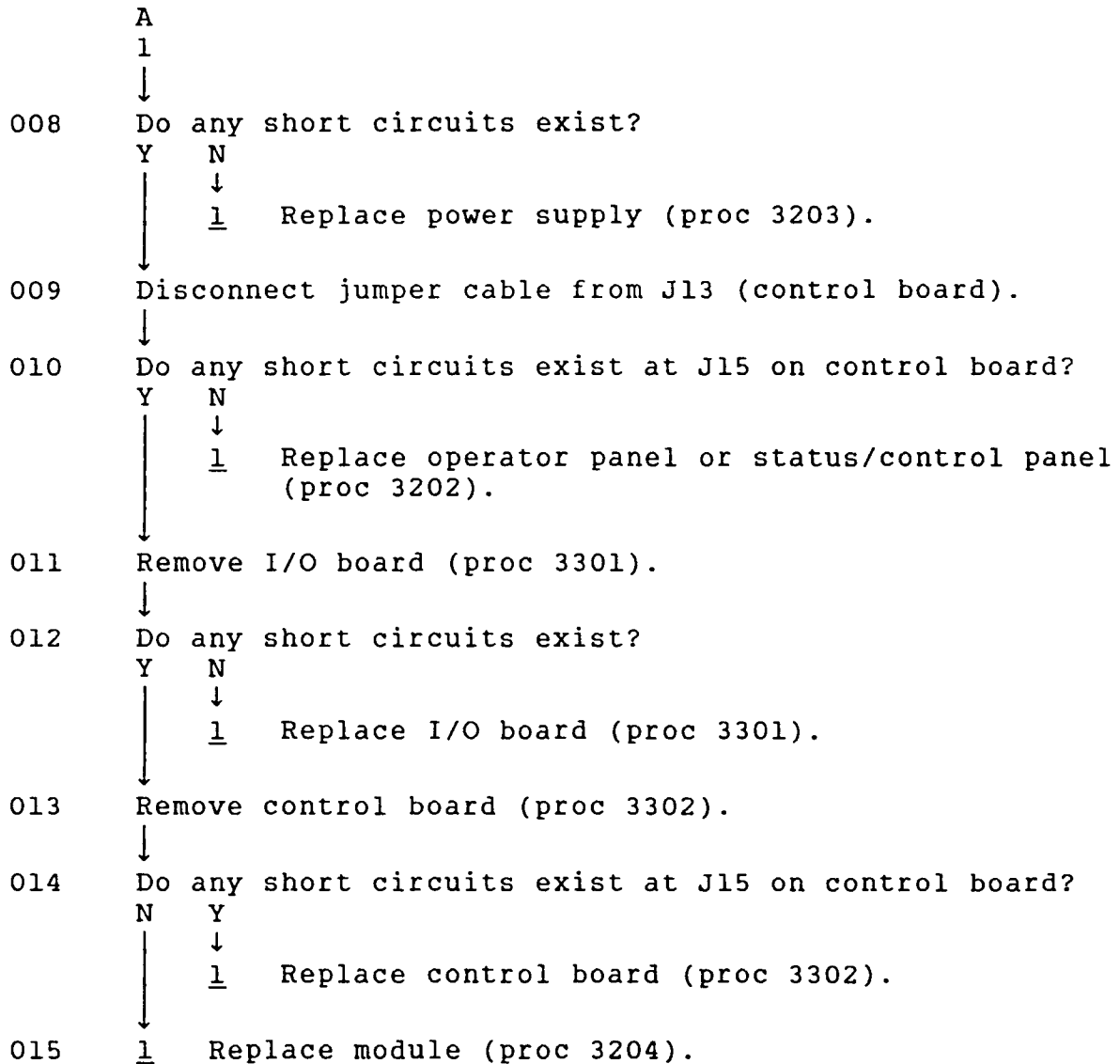

Figure 2-1. Example of Troubleshooting Procedure

TSP1 - Power Check

This procedure isolates problems in the drive or power supply related to short circuits. Refer to the voltage checks procedure (earlier in this section) for voltage specifications.





TSP2 - Voltage Fault Check

This procedure isolates problems in the drive or power supply, related to dc power failures.

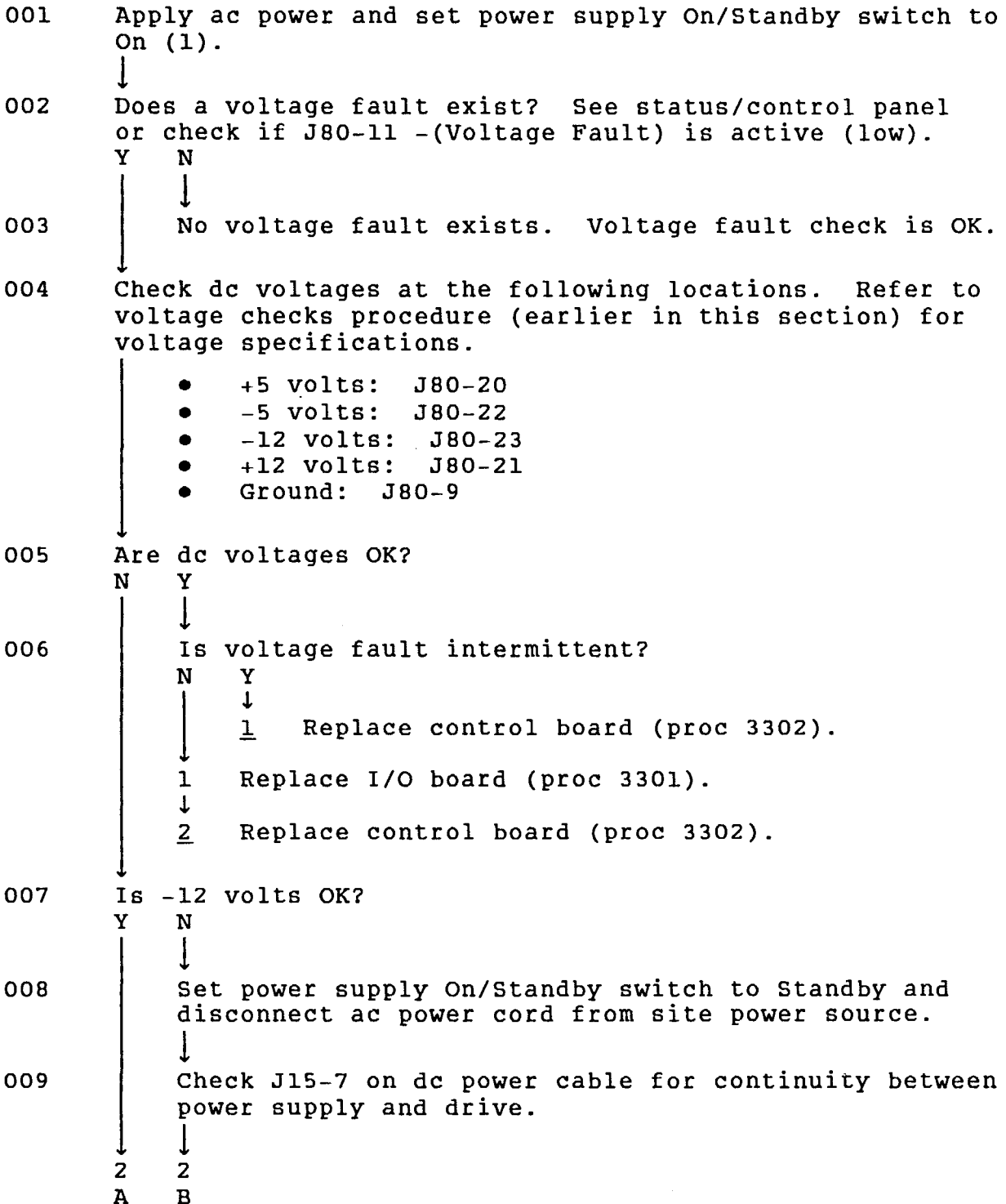

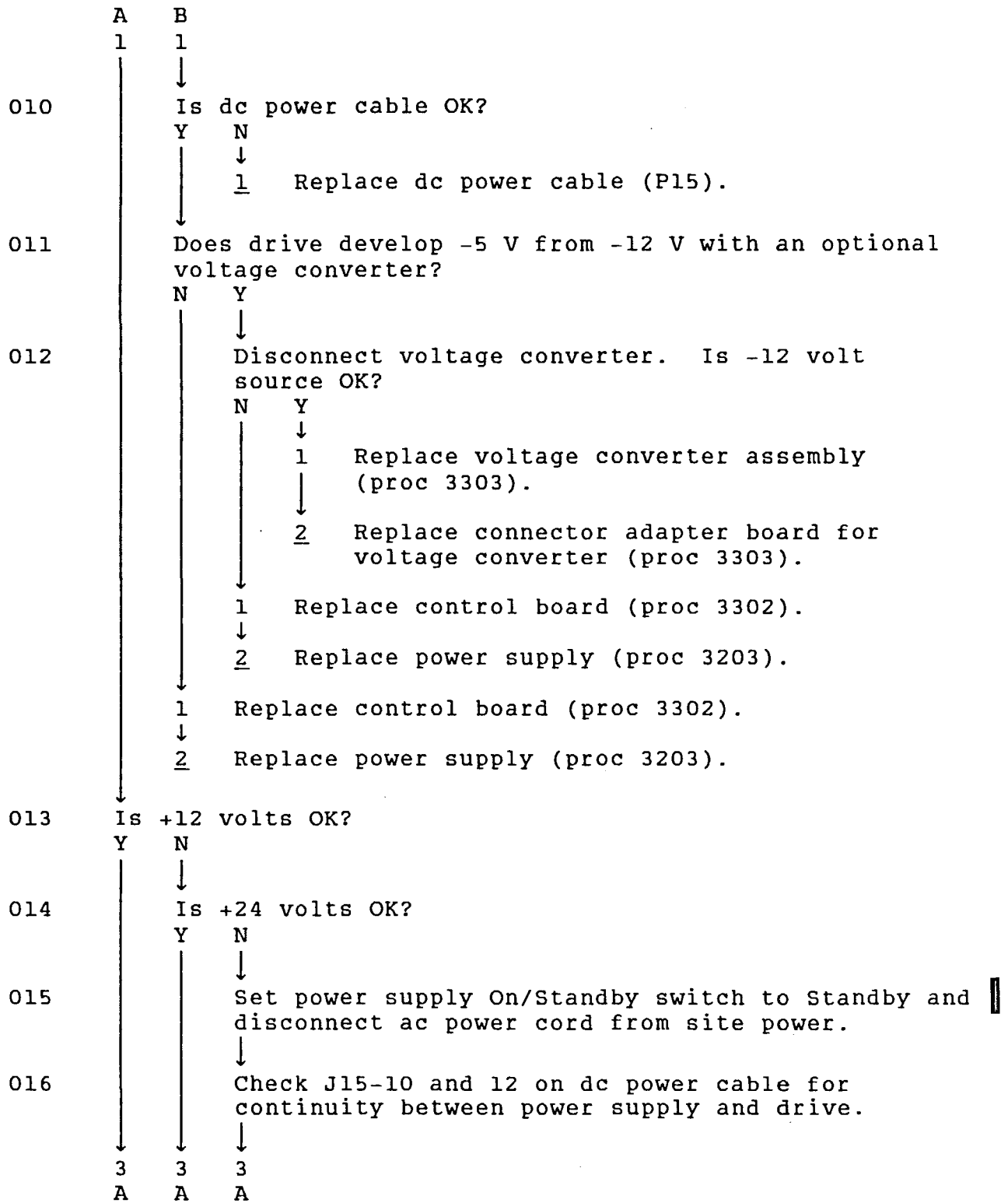

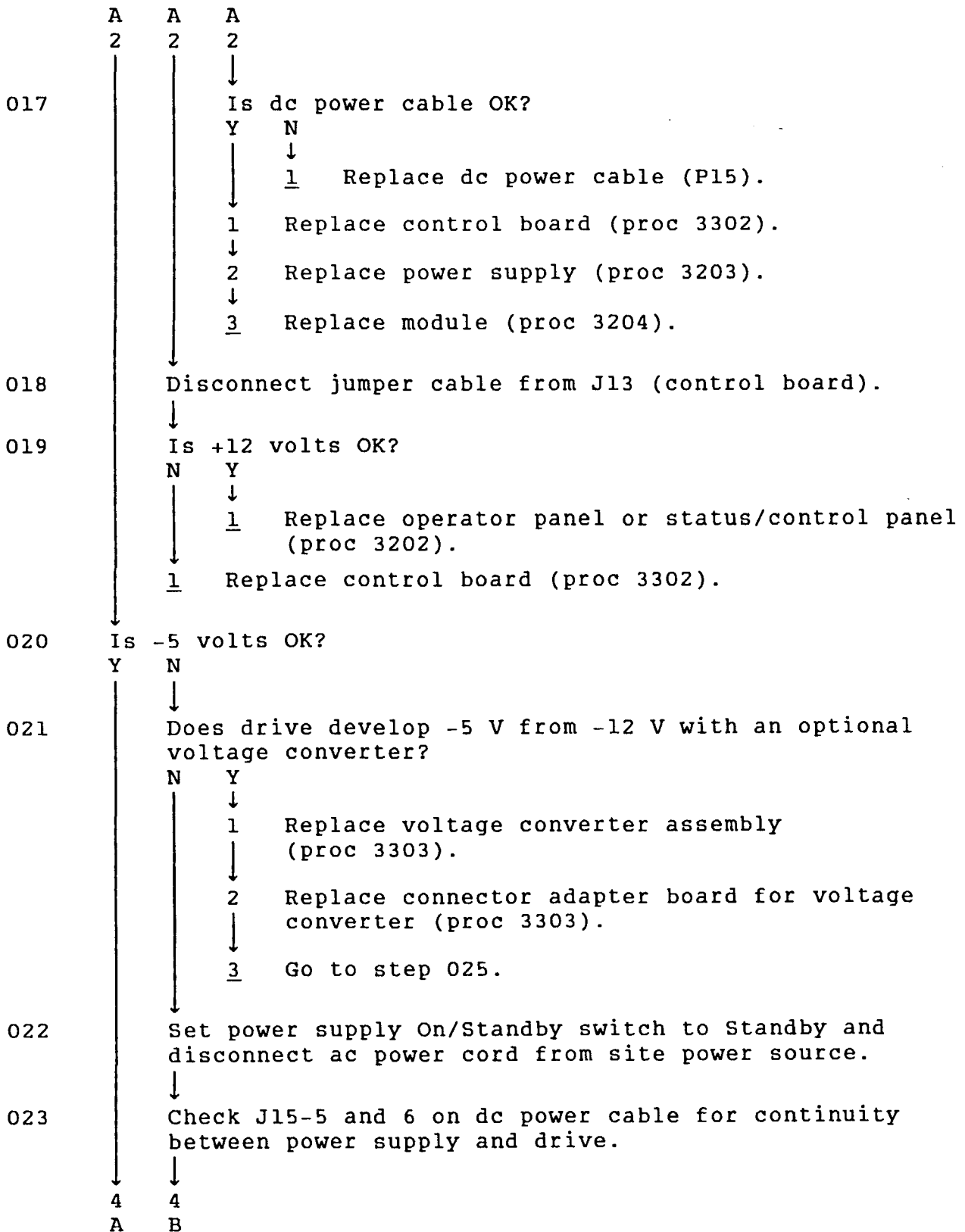

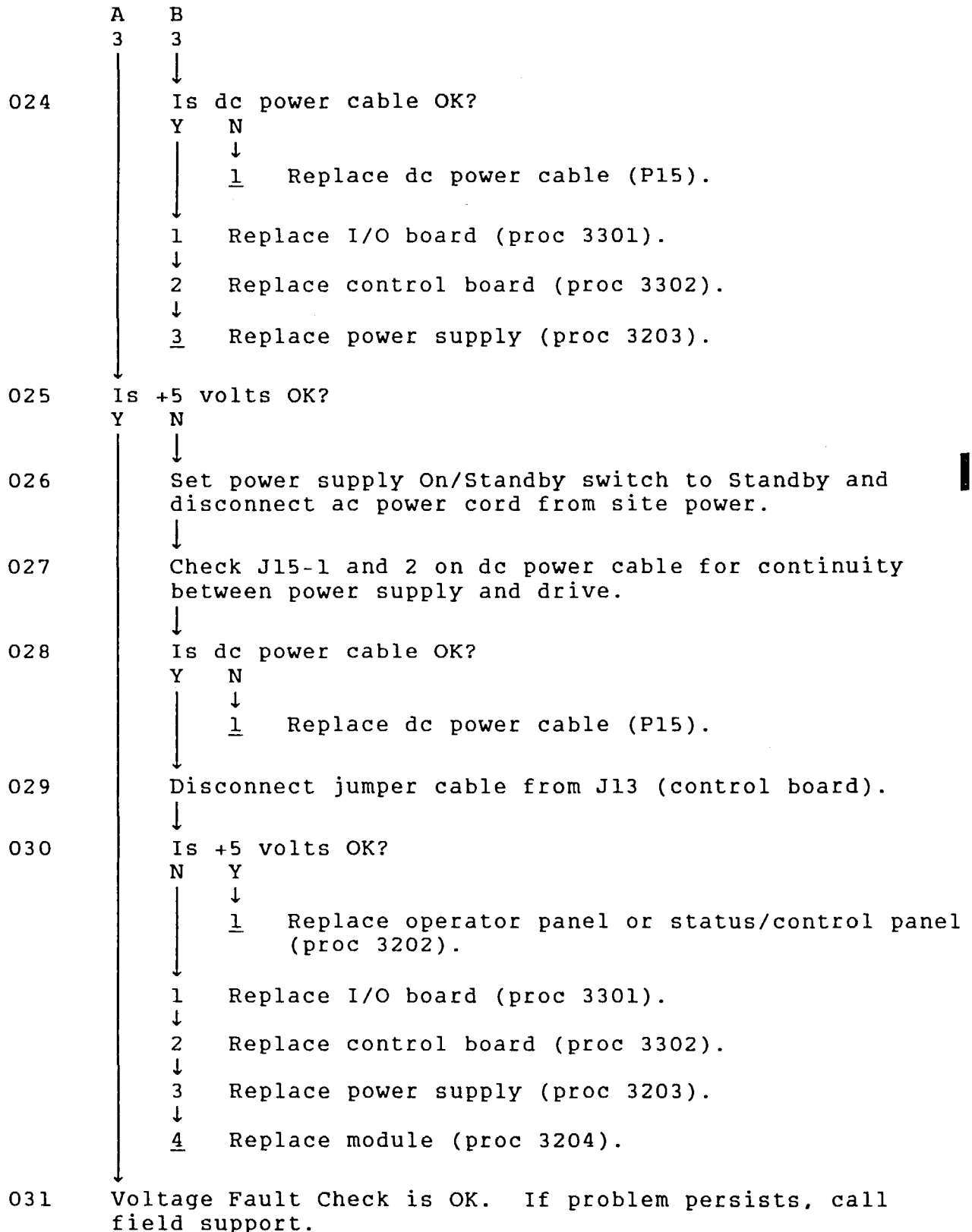

TSP3 - First Seek Check

This test assumes that the status/control panel is connected to the drive.

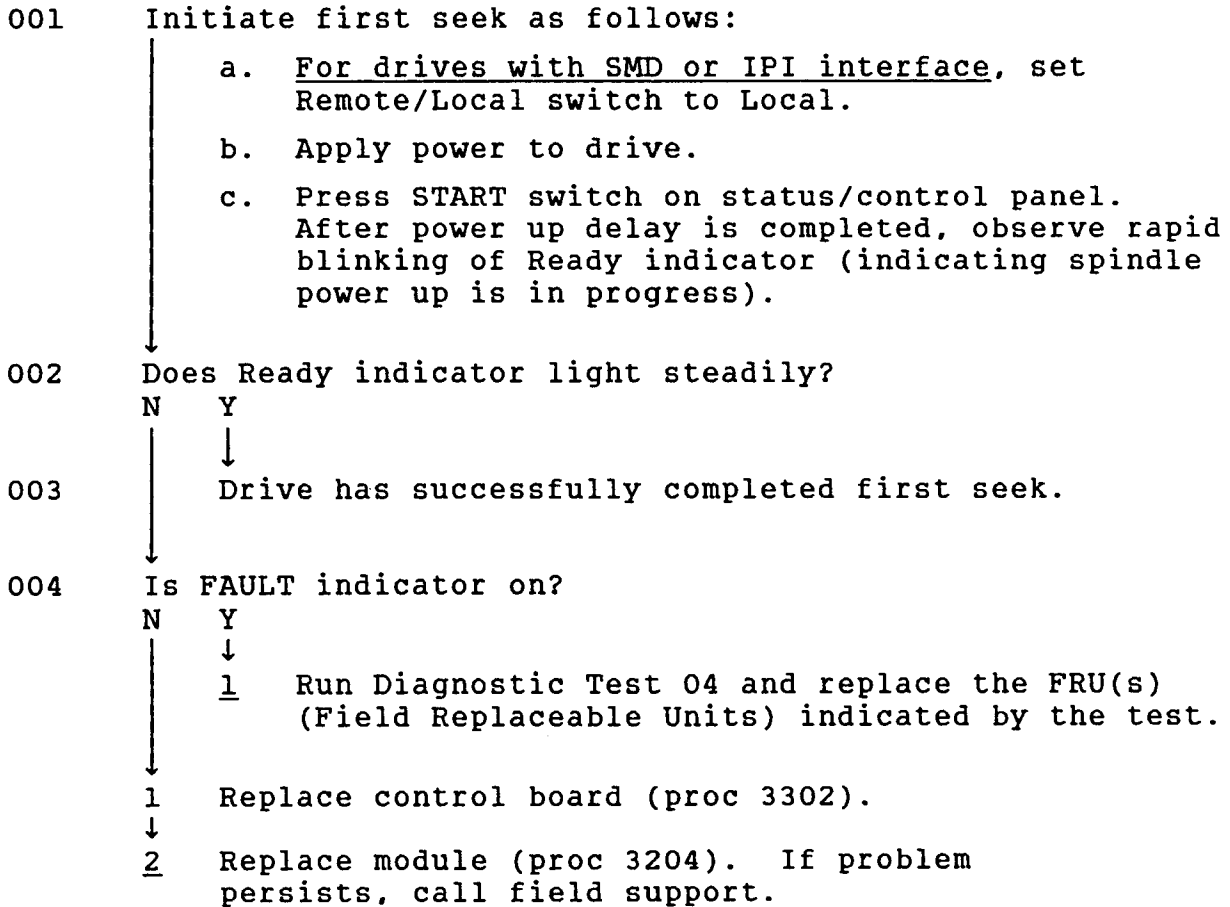

TSP4 - Seek Check

This test assumes that the following conditions exist: (1) drive is operating under control of a PFTU (or system software if a PFTU is unavailable) and (2) first seek was successfully completed.

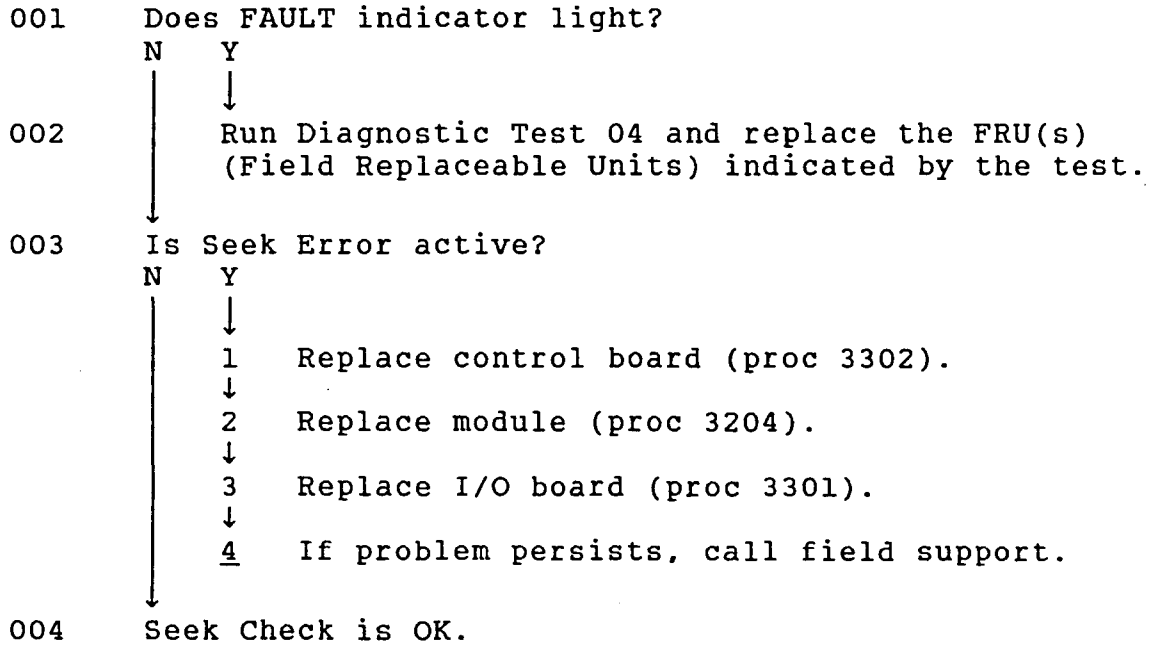

TSP5 - Write Check

This check assumes that the drive is performing write or write format operations under control of a PFTU (or system software if a PFTU is unavailable). If a fault occurs during testing, observe the status display window (on status/control panel) for type of fault present.

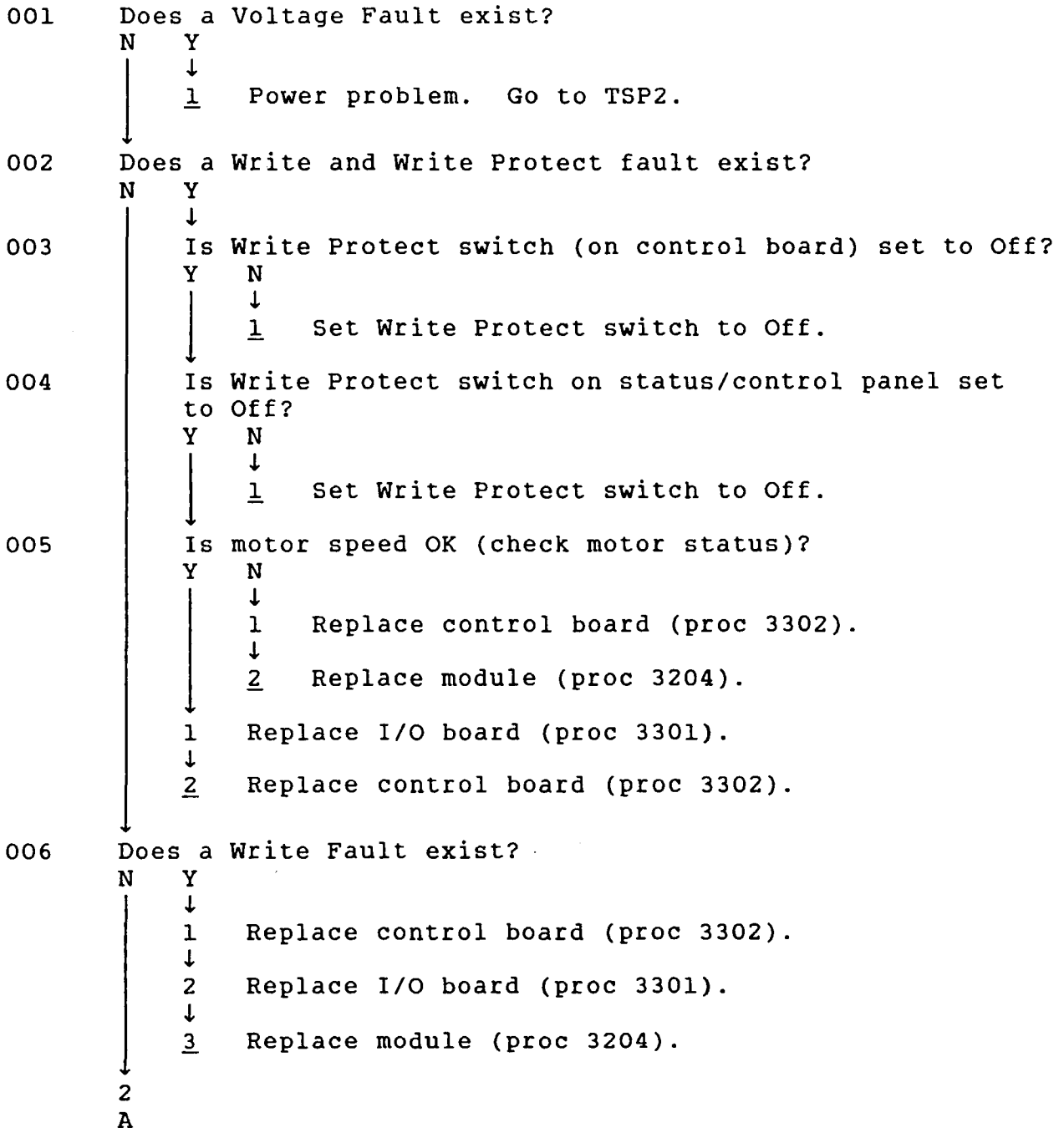

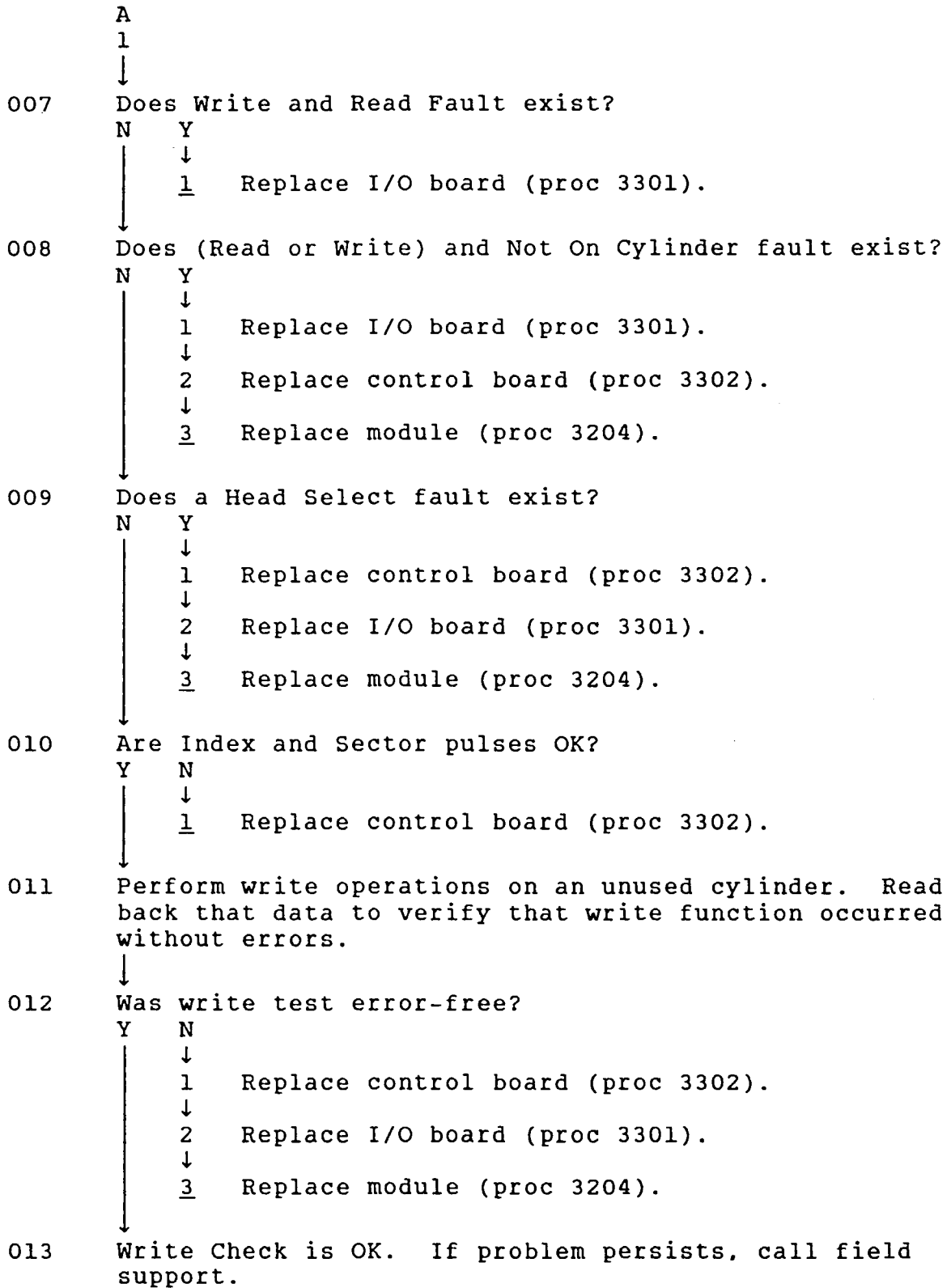

TSP6 - Read Check

This check assumes that the drive is performing read operations under control of a PFTU (or system software if a PFTU is unavailable). If a fault occurs during testing, observe the status display window (on status/control panel) for type of fault present.

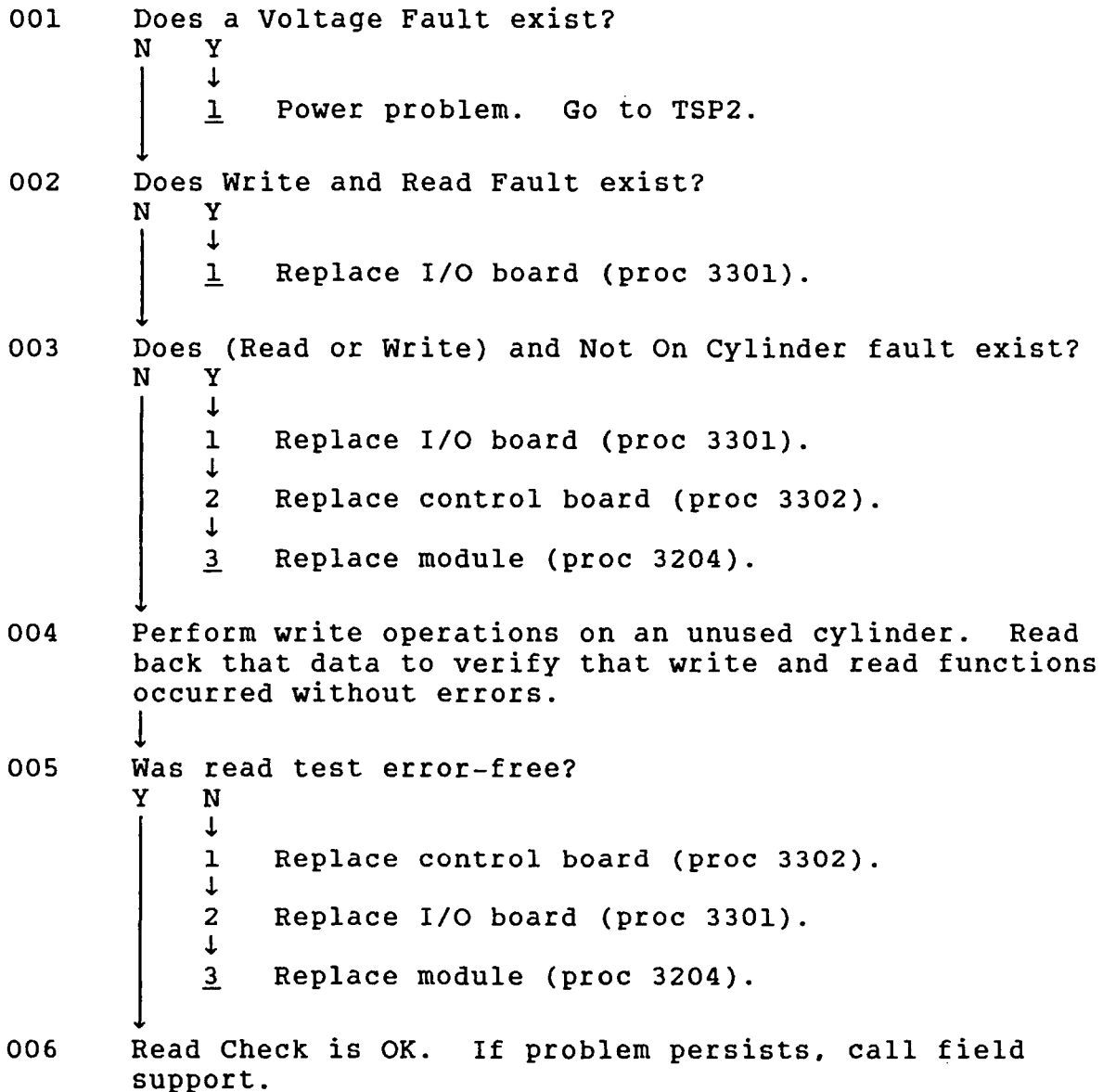

TSP7 - Address Mark Check

The following check assumes that the drive is under control of a PFTU (or system software if a PFTU is unavailable).

- 001 Perform write format operations in address mark mode on an unused cylinder. Read back that data to verify that write and read functions occurred without errors in address mark mode.
- ↓
- 002 Is address mark mode functional?
- |   |   |   |
|---|---|---|
| Y | N |   |
|   |   |   |
|   |   | 1 Replace I/O board (proc 3301).            |
|   |   | ↓   |
|   |   | <u>2</u> Replace control board (proc 3302). |
- ↓
- 003 Read AM Check OK. If problem persists, call field support.

## DIAGNOSTIC TESTING

### GENERAL

The drive's offline diagnostics are initiated and monitored via the keyboard and LCD of the status/control panel (see figure 2-2). Table 2-3 describes the function of the switches and indicators.

In addition to offline diagnostic tests, the drives can perform online testing at the request of the system. Each interface defines a unique set of diagnostic commands and drive responses. For more information about online testing, refer to Interface Testing at the end of this section.

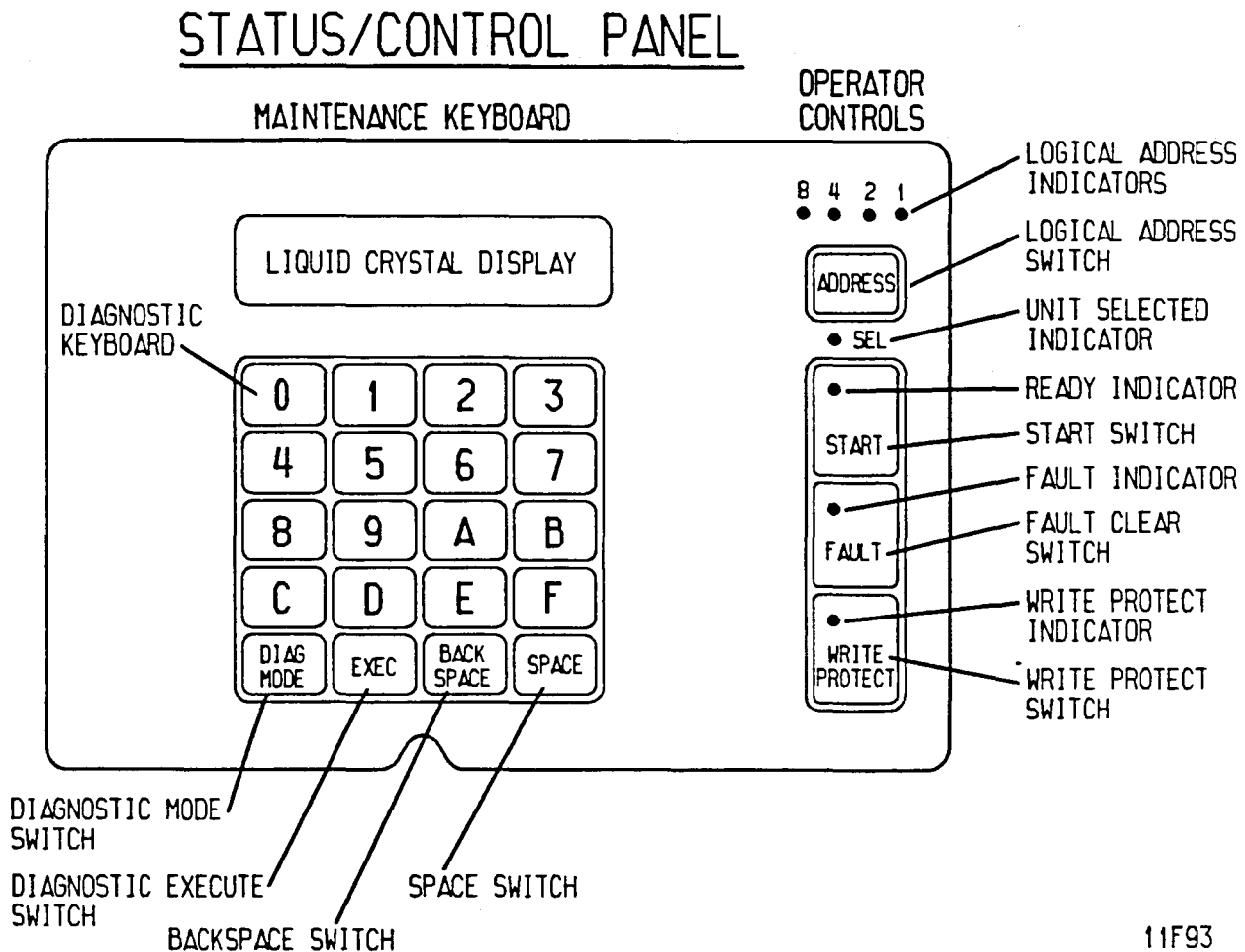

Figure 2-2. Switches and Indicators

TABLE 2-3. SWITCH/INDICATOR DESCRIPTIONS

Description	Function
Diagnostic Keyboard	Used to enter diagnostic tests and parameters.
Liquid Crystal Display	Displays drive status, faults, and current cylinder address.
DIAG MODE (Diagnostic Mode) Switch	Places drive in diagnostic mode and disables the I/O.
SPACE and BACK SPACE Switches	Used to enter the desired diagnostic tests.
EXEC (Execute) Switch	Starts and stops diagnostic tests.

## TEST SELECTION PROCEDURE

To run offline diagnostic tests on the drive, place the drive in diagnostic mode and select the tests desired. To do this:

1. On IPI interface drives, disable the I/O by setting the port disable switches (DA - DB) on the I/O board to the On (Closed) position. Failure to disable the I/O may prevent completion of diagnostics initiated on the status/control panel, and the LCD may go blank if the controller selects the drive.
2. On SCSI interface drives, to avoid possible system problems, ensure that there is no activity on the SCSI bus before proceeding with offline diagnostics.
3. Press the DIAG MODE switch to enter diagnostic mode and observe that the LCD reads DIAG TEST XX.
4. Enter two hexadecimal characters on the keyboard and press EXEC switch to select the first test.

Directions for running the individual diagnostic tests appear later in this section. When the EXEC switch is pressed one more time, the test ends and the LCD again reads DIAG TEST XX. At this point you have two choices:

- Enter two hexadecimal characters on the keyboard and press EXEC switch to select another test, or
- Press the DIAG MODE switch to exit diagnostic mode and observe that the LCD displays drive operating status. On IPI interface drives, reenable the I/O by setting the port disable switches (DA - DB) on the I/O board to the Off (Open) position. On SCSI interface drives, bus activity can resume.

## TEST DESCRIPTIONS

The individual offline diagnostic tests are listed in table 2-4 and are described in the following topics.

Do not attempt to enter any test numbers that are not listed in table 2-4. Doing so will result in invalid test information. The drive will not run tests that produce seeks (05, 08, 09, or 0E) unless the spindle motor is up to speed and the heads are loaded. The following LCD displays indicate why seek tests will not run:

- SPEED NOT OK -- the spindle was not up to speed when the test was executed.
- ACT PARKED -- the carriage was parked and locked when the test was executed.

If you connected a status/control panel to the drive temporarily to do troubleshooting, run Tests 06 and 07 before you continue with other tests. When powered off, the panel stores its status log and fault log in a nonvolatile RAM. When the panel is powered on initially, these logs may reflect operation of the panel with a different drive.

TABLE 2-4. SUMMARY OF DIAGNOSTIC TESTS

Test Number	Title
00	Display Drive Operating Status Log
01	Display Fault Log
04	Calculate Three Most Likely Field Replaceable Units
05	Servo Test
06	Clear Drive Operating Status Log
07	Clear Fault Log
08	Direct Or Continuous Seeks
09	Random Seek
0C	Display EPROM Part Number
0E	Return To Zero
2F	I/O Test (SCSI Interface Drives Only)

## Test 00 -- Display Drive Operating Status Log

### NOTE

If you connected status/control panel to drive for troubleshooting, run Test 05 initially to clear invalid data from status log and to introduce new data to the log. Continue with Test 00.

This test displays the 8 most recently generated drive status codes. After test selection, the display provides a hexadecimal status code from the internal log. This code is preceded by a character (0-7) and a colon, indicating the position of the status code in the status log. To execute test 00, perform the following steps:

1. Enter Test 00, then press EXEC switch. The LCD will display DRIVE LOG: 0:XX where the number 0 indicates the position in the log and XX represents the status code entered in that position.
2. Press SPACE switch repeatedly until you see a code preceded by an asterisk (for example, DRIVE LOG: \*5:XX). The asterisk identifies that code as the most recent entry in the status log.
3. Use the SPACE switch to step through from the 8th most recent to the most recent status.
4. Press EXEC switch to end the test and return to test selection.

## Test 01 -- Display Fault Log

## NOTE

If you connected status/control panel to drive for troubleshooting, run Test 05 initially to clear invalid data from fault log and to introduce new data to the log. Continue with Test 01.

This test displays the 8 most recently stored fault codes. After test selection, a hexadecimal fault code will be displayed. This code is preceded by a character (0-7) and a colon, indicating the position of the fault code in the fault log. To execute test 01, perform the following steps:

1. Enter Test 01, then press EXEC switch. The LCD will display FAULT LOG: 0:XX where the number 0 indicates the position in the log and XX represents the fault code entered in that position.
2. Press SPACE switch repeatedly until you see a code preceded by an asterisk (for example, FAULT LOG: \*5:XX). The asterisk identifies that code as the most recent entry in the fault log.
3. Use the SPACE switch to step through from the 8th most recent to the most recent fault.
4. If more than one fault occurs simultaneously (multiple faults), more than one bit in the fault code will be set. Check the bit-mapped locations of each fault by referring to the following list:

<u>Bit</u>		<u>Definition</u>
0	(LSB)	Read•Write Fault (01)
1		(Read+Write)•Off Cylinder Fault (02)
2		First Seek Fault (04)
3		Write Fault (08)
4		Write•Write Protected Fault (10)
5		Head Select Fault (20)
6		Voltage Fault (40)
7	(MSB)	Not Used (80)

5. Press EXEC switch to end the test and return to test selection.

**Test 04 -- Calculate Three Most Likely Field Replaceable Units**

NOTE

If you connected status/control panel to drive for troubleshooting, run Test 05 initially to clear invalid data from status and fault logs and to introduce new data to the logs. Continue with Test 04.

If the status/control panel is part of drive installation, do not execute Tests 05, 06, or 07 prior to running Test 04.

This test uses the fault status and the drive operating status history (Tests 00 and 01) to predict the most likely cause of drive failure. Table 2-5 lists the individual codes and their corresponding replacement part. To execute Test 04, perform the following steps:

1. Enter Test 04, then press EXEC switch. The LCD will display FRUS: XX XX XX. Upon test completion, the three field replaceable units will be displayed, with the first hex code being the most likely cause of the failure.
2. Press EXEC switch to end the test and return to test selection.

TABLE 2-5. CODING OF FIELD REPLACEABLE UNITS

Hex Display	Field Replaceable Unit
01	Control Board
02	Module
03	Power Supply
04	I/O Board
05	Control Board
06	Module

**Test 05 -- Servo Test**

This test clears both the drive status log and fault log. Because Test 04 relies on status history that would be cleared by Test 05, you might want to run Test 04 before running Test 05. Test 05 automatically performs several types of seek operations. They are as follows:

<u>Operation</u>	<u>Number Of Times Executed</u>
RTZ	1
1 Track Seek	16
RTZ	1
Partial Servo Recalibrate	1
RTZ	1
Maximum Length Seek	16
RTZ	1

Execution stops when an error is detected or the test completes. To execute Test 05, perform the following steps:

1. Enter Test 05, then press EXEC switch. Upon successful completion of the test, the LCD will display OK, CYL: 000. If an error occurs, the LCD will display SERVO ERROR: XX. Drive status codes (servo errors) are defined in table 2-6 later in this section.
2. Press EXEC switch to end the test and return to test selection.

**Test 06 -- Clear Drive Operating Status Log**

This test clears the drive status log resident in program RAM. Because Test 04 relies on status history that would be cleared by Test 06, you might want to run Test 04 before running Test 06. To execute Test 06, perform the following steps:

1. Enter Test 06 and press EXEC switch. The LCD will display DRIVE LOG CLEAR.
2. Press EXEC switch to end the test and return to test selection.

### Test 07 -- Clear Fault Log

This test clears the fault log. Because Test 04 relies on status history that would be cleared by Test 07, you might want to run Test 04 before running Test 07. To execute Test 07, perform the following steps:

1. Enter Test 07 and press EXEC switch. The LCD will display FAULT LOG CLEAR.
2. Press EXEC switch to end the test and return to test selection.

### Test 08 -- Direct Or Continuous Seeks

This test performs direct or continuous seeks between cylinder 0 and the desired cylinder address. Operation stops if an error occurs or if the EXEC switch is pressed. To execute Test 08, perform the following steps:

1. Enter Test 08 and press EXEC switch.
2. The display HEX CYL XXX asks you to supply a valid destination address (between 0 and 662 inclusive on 736 MB, 1120 MB, 1153 MB, and 1230 MB drives; between 0 and 564 on 850 MB drives). Enter three characters and press SPACE switch. If you enter a destination address identical to the current address (a zero-track seek), Test 08 will not run and drive status code 61 will be displayed.
3. The display DIR OR CONT? D/C asks you to select either DIRECT (D) or CONTINUOUS (C) seeks. Enter either C or D to start test.
4. If D was entered and the direct seek was successful, the LCD will display OK, CYL: XXX, where XXX is the destination address previously entered. Press EXEC switch to end the test and return to test selection.
5. If either D or C was entered and an error occurs, the LCD will display SERVO ERROR: XX. Drive status codes (servo errors) are defined in table 2-6 later in this section. By running Test 05 or Test 0E, you can clear the seek error.
6. If C was entered, press EXEC switch to end the test and return to test selection.

**Test 09 -- Random Seek**

This test performs random seeks between cylinder 0 and the maximum cylinder address (0-1634 on 736 MB, 1120 MB, 1153 MB, and 1230 MB drives; 0-1380 on 850 MB drives). Operation stops if an error occurs or if the EXEC switch is pressed. To execute Test 09, perform the following steps:

1. Enter Test 09 and press EXEC switch.
2. The LCD will display OK, CYL: XXX if execution was successful.
3. If an error occurs during the test, the LCD will display SERVO ERROR: XX. Drive status codes (servo errors) are defined in table 2-6 later in this section.
4. Press EXEC switch to end the test and return to test selection.

**Test 0C -- Display EPROM Part Number**

This test displays the 8-digit part number of the control microprocessor EPROM. To execute Test 0C, perform the following steps:

1. Enter Test 0C and press EXEC switch. The LCD will display the 8-digit part number of the EPROM (for example, EPROM# = 12345678).
2. Press EXEC switch to end the test and return to test selection.

**Test 0E -- Return To Zero**

This test initiates a return to zero command. To execute Test 0E, perform the following steps:

1. Enter Test 0E and press EXEC switch. The LCD will display OK, CYL: 000.
2. If an error occurs during the test, the LCD will display SERVO ERROR: XX. Drive status codes (servo errors) are defined in table 2-6 later in this section.
3. Press EXEC switch to end the test and return to test selection.

## Test Descriptions

### Test 2F -- I/O Test

This test causes the I/O MPU to run a self-test of the I/O circuitry (in SCSI interface drives only). To execute Test 2F, perform the following steps:

1. Enter Test 2F and press EXEC switch.
2. If an error occurs during the test, the LCD will display  
SCSI CM:2F ST:28.
3. If the test runs error-free, the LCD will display  
SCSI CM:2F ST:18.
4. Press EXEC switch to end the test and return to test selection.

### DRIVE STATUS CODES

Whenever the drive is in a power on condition (dc power active), the Control MPU is periodically checking the operation of the drive and generating appropriate operating status codes. These status codes are displayed on the status/control panel (if present) and can be reported to the system in response to an interface command. Refer to Interface Testing at the end of this section for more information about status reporting to the controller or host.

If a status/control panel is attached to the drive, the codes can be visually monitored by removing the drive front panel insert. Table 2-6 lists the status codes and a definition of each code. If a drive malfunction occurs, observe the error code and perform Diagnostic Test 04 to calculate the action to be taken.

Figure 2-3 shows an example of the LCD during normal operation and when a fault occurs. During normal operation, the LCD displays current drive status, current cylinder address, and (except for IPI interface drives) which drive channel is selected and/or reserved. If a fault occurs, the LCD displays the type of fault(s) that occurred along with the current drive status. If more than one fault occurred, use the SPACE switch to step through the fault log to determine what faults are present.

Pressing the Fault Clear switch on the status/control panel clears the LCD fault display and the FAULT indicator, provided that the fault condition is no longer present. However, a Fault Clear signal from the controller clears only the FAULT indicator.

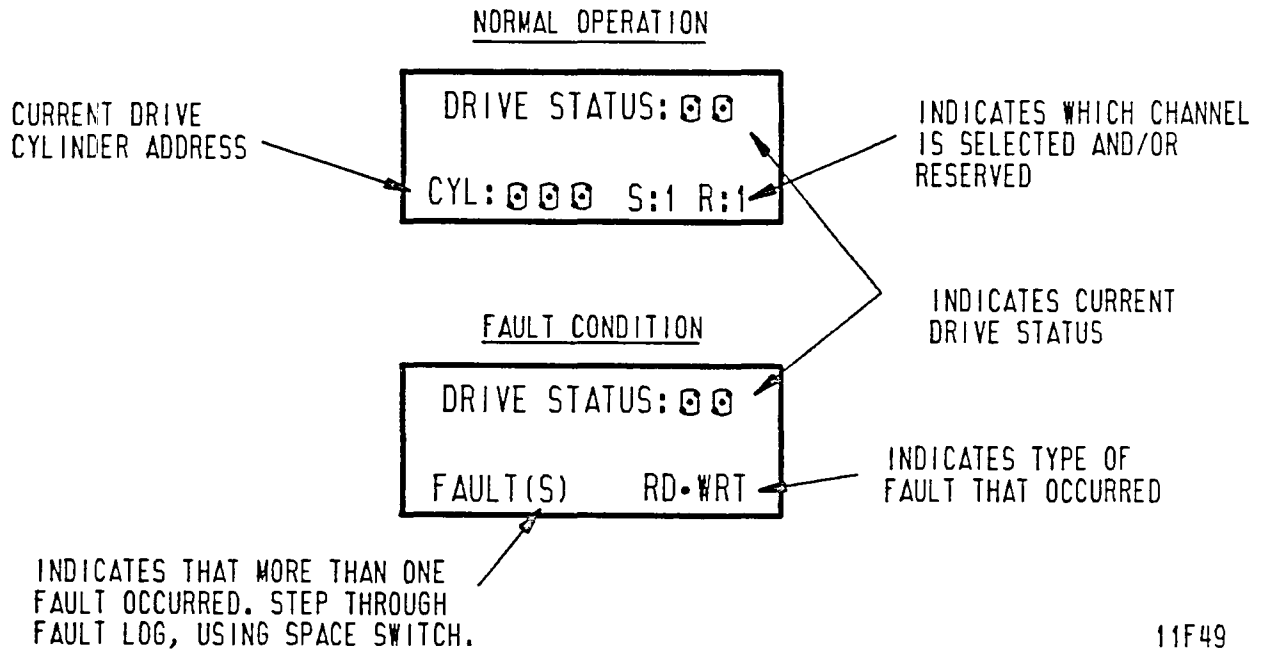

Figure 2-3. Example of LCD (Liquid Crystal Display)

TABLE 2-6. DRIVE STATUS CODES

Code	Title	Description
NORMAL START/STOP STATUS		
00	Ready & On Cylinder	When the Control MPU displays this status code, it indicates that the drive is on cylinder and ready to perform normal operations.
02	Motor Stopping	The Control MPU sets this status code while the motor is coasting down or while motor braking is in progress.
Table Continued on Next Page		

TABLE 2-6. DRIVE STATUS CODES (Contd)

Code	Title	Description
NORMAL START/STOP STATUS (Contd)		
03	Motor Stopped	The Motor MPU sets this status code when it detects that the motor is stopped. The status remains at 03 until start conditions are available.
04	First Load/Calibrate	When this status code is displayed, the heads move from the landing zone to track 0 and a servo calibration (self-test) is initiated. The calibration consists of a sequence of normal seeks and RTZ seeks. Throughout these seeks, the Servo MPU makes time-per-track measurements and adjusts several constants that govern servo operation.
05	Sequence Delay	<p><u>For SMD and IPI interface drives,</u> this status code is displayed in Remote mode during the power on sequence delay. The length of delay is determined by the logical address number used in increments of 5 seconds. After the delay, the status changes to 07.</p> <p><u>For SCSI interface drives,</u> this status code never appears.</p>
Table Continued on Next Page		

TABLE 2-6. DRIVE STATUS CODES (Contd)

Code	Title	Description
NORMAL START/STOP STATUS (Contd)		
06	START Switch Pressed and Waiting for Power Sequence Signals	<p>The Control MPU sets this status code to indicate that the START switch was pressed and that the drive is waiting for power sequence signals from the controller.</p> <p><u>For SMD and IPI interface drives,</u> this code appears in Remote mode and precedes the sequence delay.</p> <p><u>For SCSI interface drives,</u> this code follows a timeout in the controller circuitry.</p>
07	Starting Motor	The Control MPU displays this status code when all start conditions (codes 05 and 06) have been satisfied. The status remains at 07 until the motor reaches full speed.
08	Motor Up To Speed	The Control MPU displays this status code when the motor is up to full speed.
I/O BOARD NORMAL STATUS (FOR SCSI AND IPI DRIVES)		
09	I/O Self-Test Passed	The I/O MPU successfully executed its power on initialization self-test.
Table Continued on Next Page		

TABLE 2-6. DRIVE STATUS CODES (Contd)

Code	Title	Description
SWEEP CYCLE STATUS		
0A	Drive in Sweep Segment	The drive is executing a series of seeks for a sweep cycle. On Cylinder and Seek End are inactive at this time.
0B	Heads Left on Last Cylinder of Sweep	Current head position determined by last sweep cycle -- not by a controller-requested seek. On Cylinder and Seek End are inactive at this time.
SEEK ERROR STATUS		
46	Seek Timeout	<p>Indicates that during a normal seek the drive took longer than 100 milliseconds to reach on cylinder. When the drive displays code 46, the following error indications also appear:</p> <ul style="list-style-type: none"> <li>• Seek Error and Seek End lines go active.</li> <li>• Motor continues to run but servo system is disabled and the heads, although loaded, float freely over the disk surfaces.</li> </ul> <p>An RTZ clears the Seek Error and initiates a seek to cylinder 0.</p>
4B	Off Track Seek Error	Indicates that either the drive failed to stay on cylinder or cylinder pulses were detected during track-following. When the drive displays code 4B, the following error indications also appear:
Table Continued on Next Page		

TABLE 2-6. DRIVE STATUS CODES (Contd)

Code	Title	Description
SEEK ERROR STATUS (Contd)		
4D	Illegal Cylinder Address	<ul style="list-style-type: none"> <li>• On Cylinder goes inactive.</li> <li>• Seek Error and Seek End go active.</li> <li>• Motor continues to run, but the servo system is disabled and the heads, although loaded, float freely over the disk surfaces.</li> </ul> <p>An RTZ command clears the Seek Error and initiates a seek to cylinder 0.</p> <p>Indicates that during a normal seek, the Control MPU received too high a cylinder address (&gt;1634 for 736 MB, 1120 MB, 1153 MB, and 1230 MB drives; &gt;1380 for 850 MB drives). When the drive displays code 4D, the following error indications also appear:</p> <ul style="list-style-type: none"> <li>• On Cylinder goes inactive.</li> <li>• Seek Error and Seek End go active.</li> <li>• The drive remains on cylinder because no commands have been sent to the Servo MPU.</li> </ul>
4F	Seek Error On Settle In	<p>Indicates that the drive could not settle in on the destination cylinder. The following error indications also appear:</p> <ul style="list-style-type: none"> <li>• Seek Error and Seek End lines go active.</li> </ul>
Table Continued on Next Page		

TABLE 2-6. DRIVE STATUS CODES (Contd)

Code	Title	Description
SEEK ERROR STATUS (Contd)		
		<ul style="list-style-type: none"> <li>• Motor continues to run but servo system is disabled and the heads, although loaded, float freely over the disk surfaces.</li> </ul> <p>An RTZ clears the Seek Error and initiates a seek to cylinder 0.</p>
FIRST SEEK FAULT STATUS		
54	First Seek Fault On Retract	Indicates that the Servo MPU failed to complete the retract portion of the first seek.
55	First Seek Fault On Load	Indicates that the drive failed to load the heads.
56	First Seek Fault On RTZ	Indicates that the drive failed to complete the return to zero (RTZ) portion of the first seek.
57	First Seek Fault On Calibrate	Indicates that the drive did not complete the velocity calibration operation.
ERROR CONDITION STATUS		
58	Speed Loss	Indicates that the spindle speed fell below 3564 r/min. The Motor MPU inactivates the Speed OK code to the Control MPU. This causes the Control MPU to activate the Write Protect line. The Control MPU also drops the Ready signal and performs a retract operation.
Table Continued on Next Page		

TABLE 2-6. DRIVE STATUS CODES (Contd)

Code	Title	Description
ERROR CONDITION STATUS (Contd)		
59	Motor Can't Start Due to Error	Indicates that the Control MPU did not receive start conditions from the Motor MPU due to an error caused by overcurrent or other bad status between the Motor and Control MPUs.
5A	Emergency Retract	Indicates that the heads retracted back to the landing zone due to a power loss (-Low Vcc active), or that the Servo MPU is unable to perform a retract operation.
MOTOR AND SERVO MPU ERRORS		
60	Motor MPU Failure	Indicates that the Control MPU was unable to communicate with the Motor MPU.
61	Servo MPU Failure	Indicates that the Control MPU was unable to communicate with the Servo MPU.
I/O BOARD ERROR STATUS (FOR SCSI AND IPI DRIVES)		
62	I/O Status Transfer Failed	The I/O MPU failed to transfer status successfully to the Control MPU during a diagnostic test.
6E	I/O Self-Test Failed	The I/O MPU failed its power on initialization self-test.

## INTERFACE TESTING

This topic describes the unique self-tests and online diagnostic tests available with each interface type. The product is available with the SMD, SCSI, or IPI interface.

### TESTING SMD INTERFACE DRIVES

If an SMD interface drive has the SMD-E (enhanced SMD) interface version selected, it offers diagnostic information to the controller. When the controller issues Tag 5 (Extended Status), the drive responds in one of the following ways:

- Extended Fault Status -- When Bus Out Bit 0 = 0 and Bus Out Bit 1 = 0, the drive defines on Bus In Bit 0-6 which specific fault is present. Bus In Bit 7 indicates that valid status is available.
- Operating Status -- When Bus Out Bit 0 = 1 and Bus Out Bit 1 = 0, the drive provides the current drive status code on Bus In Bit 0-6. These codes are defined earlier in this section in table 2-6. Bus In Bit 7 indicates that valid status is available.
- Diagnostic FRU Status -- When Bus Out Bit 0 = 0 and Bus Out Bit 1 = 1, the drive provides a code defining the most likely failed field replaceable unit (FRU). The codes, which appear on Bus In Bit 0-3, are defined in table 2-7. Bus In Bit 4-7 are not used. Bus In Bit 7 indicates that valid status is available.
- Execute Diagnostic Test Command -- When Bus Out Bit 0 = 1 and Bus Out Bit 1 = 1, the drive executes a standard series of diagnostic tests. Bus In Bit 7 goes active when the test begins. Seek End remains inactive during test execution and goes active when the test stops.

TABLE 2-7. SMD-E ONLINE FRU CODES

BIB 3-0	Field Replaceable Unit
0001	Control Board
0010	Module
0011	Power Supply
0100	I/O Board
0101	Control Board
0110	Module
0111	Not Used
1000	Not Used
1001	Not Used
1010	Not Used
1011	Not Used
1100	Not Used
1101	Not Used
1110	Not Used
1111	Not Used

## TESTING SCSI INTERFACE DRIVES

The SCSI controller (I/O board) has a self-test feature. Four LEDs on the I/O board indicate various SCSI controller conditions. In addition, there are interface commands that tell the target (drive) to send status to the initiator.

### I/O Board Self-Test

Two power on test sequences occur as dc power is applied to the drive. The SCSI controller (I/O board) firmware is tested and initialized first. This is not an exhaustive diagnostic test but it verifies the integrity of the major components. The drive firmware is initialized if SCSI firmware testing and initialization are successful.

Controller testing consists of a hardware self-test that verifies the integrity of the controller hardware. The controller halts further initialization if this test fails.

The initialization sequence occurs under any of the following three conditions:

- Controller (I/O) power-up sequence occurs
- SCSI Bus Reset (-RST signal is asserted)
- BUS DEVICE RESET message is received on SCSI Bus

The controller does not respond to a Selection Phase on the SCSI bus during the self-test sequence. The self-test sequence consists of the following events:

- Test Microprocessor
- Test Buffer Controller
- Test RAM Memory
- Test SCSI Interface

The SCSI Firmware initialization sequence is as follows:

- Set status for the LUN (logical unit number) to Busy
- Initialize the SCSI

The Drive Firmware initialization sequence occurs next and is as follows:

- Initialize disk interface (I/O board-to-drive)
- Initialize LUN parameters
- Start the drive spindle (only during power on sequence)
- Read parameters from cylinder 0 sector 0 of the drive (only during power on sequence)
- Test controller/drive interface (only during power on sequence)
- Do write/read test on diagnostic cylinder (only during power on sequence)

When the SCSI controller firmware is initialized, the controller will respond to a Selection Phase. It returns BUSY status until the entire drive initialization process is complete.

The drive initialization firmware spins up the drive, and it attempts to read the saved controller parameters from a reserved area of the drive. These parameters define the disk characteristics and other operating parameters. As part of a power on sequence, the drive initialization concludes with the following tests:

- Test controller/drive interface
- Do write/read test on diagnostic cylinder (2 patterns)

Errors encountered during these tests will result in flashing I/O LEDs as explained in the maintenance manual. If an error occurs, the drive will no longer respond to SCSI commands. However, a SCSI reset will abort the error indication and any further diagnostic testing, and it will complete the initialization sequence. Powering down and then up while in the failure mode will restart the test.

The controller uses the default parameters if it cannot read the saved controller parameters from a reserved area of the disk or if that data is invalid (the disk has not been formatted). No controller/drive interface or write/read test will be done in this mode.

When the entire initialization process is complete, the first command sent by an Initiator is terminated with CHECK status and UNIT ATTENTION Sense Key.

### Inquiry Command

The INQUIRY command requests the characteristics of the target (drive) be sent to the initiator. The INQUIRY command data consists of a five-byte header followed by the product characteristics as shown in the example in table 2-8.

TABLE 2-8. TYPICAL INQUIRY DATA

Byte/Bit	7	6	5	4	3	2	1	0
0	Peripheral Device Type							(00)
1	0	Device Type Qualifier						(00)
2	0	0	ECMA Version (0)			ANSI Version (1)		
3	0	0	0	0	0	0	0	1
4	Additional Length							(1FH)
5	Reserved							(00H)
6	Reserved							(00H)
7	Reserved							(00H)
8	Vendor Identification ASCII C							(43H)
	Table Continued on Next Page							

TABLE 2-8. TYPICAL INQUIRY DATA (Contd)

Byte/Bit	7	6	5	4	3	2	1	0
9	Vendor Identification				ASCII D		(44H)	
10	Vendor Identification				ASCII C		(43H)	
11	Vendor Identification				ASCII blank		(20H)	
12	Vendor Identification				ASCII blank		(20H)	
13	Vendor Identification				ASCII blank		(20H)	
14	Vendor Identification				ASCII blank		(20H)	
15	Vendor Identification				ASCII blank		(20H)	
16	Product Identification				ASCII E		(45H)	
17	Product Identification				ASCII M		(4DH)	
18	Product Identification				ASCII D		(44H)	
19	Product Identification				ASCII blank		(20H)	
20	Product Identification				ASCII 9		(39H)	
21	Product Identification				ASCII 7		(37H)	
22	Product Identification				ASCII 2		(32H)	
23	Product Identification				ASCII 0		(30H)	
24	Product Identification				ASCII 1		(31H)	
25	Product Identification				ASCII blank		(20H)	
26	Product Identification				ASCII (		(28H)	
27*	Product Ident.				ASCII 7/8/1		(37/38/31H)	
28*	Product Ident.				ASCII 3/5/.		(33/35/2EH)	
29*	Product Ident.				ASCII 6/0/2		(36/30/32H)	
30	Product Identification				ASCII )		(29H)	
Table Continued on Next Page								

TABLE 2-8. TYPICAL INQUIRY DATA (Contd)

Byte/Bit	7	6	5	4	3	2	1	0
31	Product Identification				ASCII blank (20H)			
32	Revision Number				ASCII blank (20H)			
33	Revision Number				ASCII blank (20H)			
34**	Revision Number				First ASCII #		(xxH)	
35**	Revision Number				Second ASCII #		(xxH)	
* Drive capacity can be 736 MB, 850 MB, or 1.2 GB								
** These two bytes indicate two-digit microcode revision								

### Receive Diagnostic Results Command

The RECEIVE DIAGNOSTIC RESULTS command requests that analysis data be sent to the initiator following completion of a SEND DIAGNOSTICS command. Diagnostic data return bytes are shown in table 2-9.

TABLE 2-9. DIAGNOSTIC DATA RETURN BYTES

Byte	Description
0	Additional Length (MSB)
1	Additional Length (LSB)
2	FRU Code (Most probable)
3	FRU Code
4	FRU Code
5	FRU Code (Least probable)
6	Error Code (MSB)
7	Error Code (LSB)

Additional Length Bytes

This two-byte value indicates the number of additional bytes included in the diagnostic data list. This value can be either 0006H or 0000H. A value of 0000H means that there are no additional bytes. A value of 0006H means that there are six additional bytes (bytes 2 - 7).

FRU Code

The FRU code byte identifies the assembly that may have failed. The codes are listed in probability order with the most probable assembly listed first and the least probable listed last. FRU codes are shown in table 2-10. These codes should not be confused with the FRU codes reported during the drive offline tests.

TABLE 2-10. SCSI ONLINE FRU CODES

Code	Description
00H	No FRU Information Available
01H	Entire Drive
02H	Control Board
03H	Module
04H	Power Supply
05H	SCSI I/O Board
06H	Control Board
07H	Module

Error Code

This two-byte value provides information about what part of the diagnostic operation has failed. The error codes are shown in table 2-11 for standard SCSI drives (736 and 850 MB). Table 2-12 provides the same information for high-performance SCSI drives (1230 MB).

TABLE 2-11. STANDARD SCSI ERROR CODES

Code	Description
01H	SCSI controller external memory test (600H - AFFFH)
02H	Buffer controller register test
03H	Disk formatter register test
04H	SCSI chip test
05H	Test Drive Ready
06H	Drive online test (diagnostic cylinder write/verify)
07H	No drive response for self-test command
46H	Seek timeout status
4BH	Off-track seek error status
4DH	Illegal cylinder address status
4FH	Seek error on settle-in status
50H	Low Vcc glitch recovery (speed >2400 r/min)
51H	Control MPU hang reset (speed >2400 r/min)
54H	First seek fault on retract
55H	First seek fault on load
56H	First seek fault on RTZ
57H	First seek fault on calibrate
58H	Speed loss status
59H	Motor cannot start due to error status
5AH	Emergency retract status
60H	Motor MPU fail status
61H	Servo MPU fail status
90H thru DOH	CDIC register test

TABLE 2-12. HIGH-PERFORMANCE SCSI ERROR CODES

Code	Description
01H	Microprocessor test
02H	Static RAM test
03H	MAC register test
04H	Buffer controller test
05H	Disk formatter test
06H	Dynamic RAM test
07H	SCSI protocol chip test
08H	CDIC test
09H	DMA to/from FIFO test
0AH	Index block pulse test
0BH	Parity error test
0CH	ROM checksum test
10H	Sequencer diagnostic error
11H	External RAM diagnostic error
12H	No drive ready
13H	No sector or index found
14H	Fatal hardware error during drive diagnostics
15H	Unable to set drive sector size
16H	Unable to clear drive attention
17H	Unable to recal drive (check drive switches)
18H	Unable to send write current data to drive
19H	Unable to issue seek command to drive
1AH	Unable to read user table from drive
1BH	Ran out of sectors during drive diagnostics
1CH	Unable to read reallocation table
1DH	Unable to read ETF log sector zero
1FH	Drive unable to locate cal track center
20H	80186 timer error
21H	DMA chip diagnostic error

Continued

TABLE 2-12. HIGH-PERFORMANCE SCSI ERROR CODES (Contd)

Code	Description
22H	Buffer RAM diagnostic error
23H	Data miscompare during drive diagnostics
4BH	Off-track seek error status
4DH	Illegal cylinder address status
4FH	Seek error on settle-in status
50H	Low Vcc glitch recovery (speed >2400 r/min)
51H	Control MPU hang reset (speed >2400 r/min)
54H	First seek fault on retract
55H	First seek fault on load
56H	First seek fault on RTZ
57H	First seek fault on calibrate
58H	Speed loss status
59H	Motor cannot start due to error status
5AH	Emergency retract status
60H	Motor MPU fail status
61H	Servo MPU fail status
90H thru DOH	CDIC register test

**Reading the I/O Board LEDs on Standard SCSI Drives**

Four light emitting diodes (3 red, 1 green) are visible on the I/O board at the rear of the drive. The LEDs show various SCSI controller conditions. Any one or a combination of LEDs can be on, off, or flashing to indicate a specific condition. The LED descriptions that follow apply to 736 MB and 850 MB drives, which have the standard SCSI. The LEDs on 1230 MB drives, which have the high performance SCSI, operate differently and are described separately.

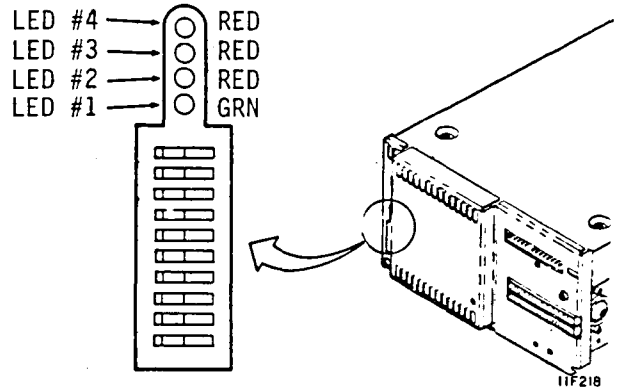

**The "Heartbeat" Display**

LED #3 on and LED #1 flashing indicates there is no activity and the unit is available. The flashing green LED #1 serves as a "heartbeat" indication. Any indication other than heartbeat, command executing, or retry, is an error indication. The corrective action for any error is to replace the I/O board.

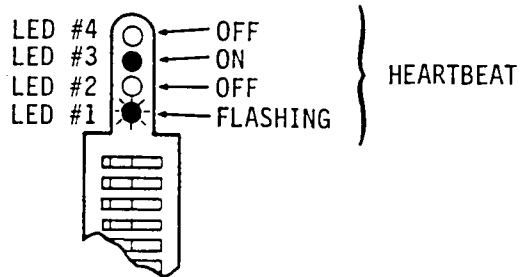

**Self-Test Failure Indication**

All four LEDs form a binary display showing which self-test failed. The range of test numbers is 0 - F and the corrective action for all self-test failures is to replace the SCSI controller (I/O board).

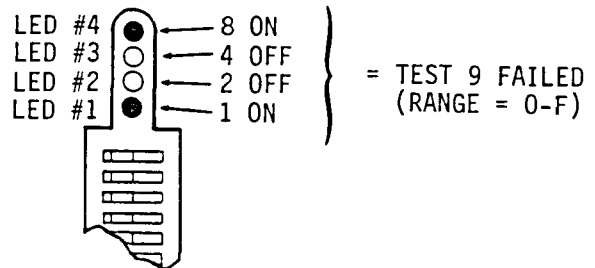

The Command Executing Display

When the green LED (#1) is flashing and all others are off, a command is executing and the drive is not available.

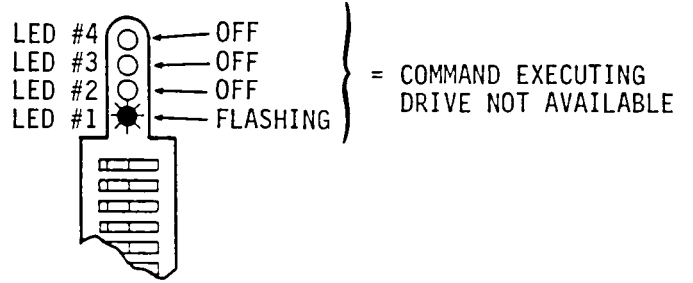

11F221

The Retry Display

If all except the green LED are on, a read or write retry is occurring.

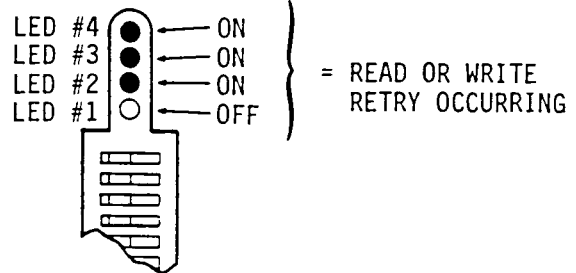

11F222

The CDIC Failure Display

A controller-device interface chip failure has occurred if all LEDs are flashing at two second intervals.

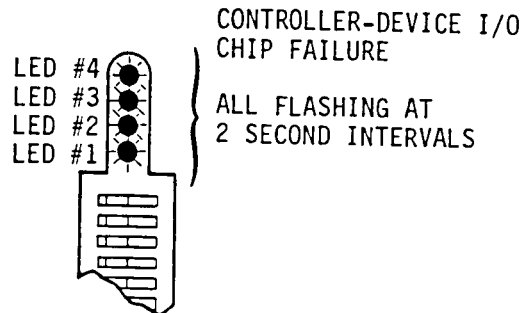

11F223

The Unrecoverable System Error Display

The failing I/O microcode address for an unrecoverable system error is indicated in a sequence of eight displays. Four of the displays represent the failing 16-bit microcode address. The other four displays identify the particular four-bit segment of the 16-bit address.

**Displaying the First Four Bits of Failing Microcode Address**

LED #1 (green) on and all others off means the next display represents the first four bits of failing microcode address for an unrecoverable system error. All LEDs remain off for one second before going to the next sequence.

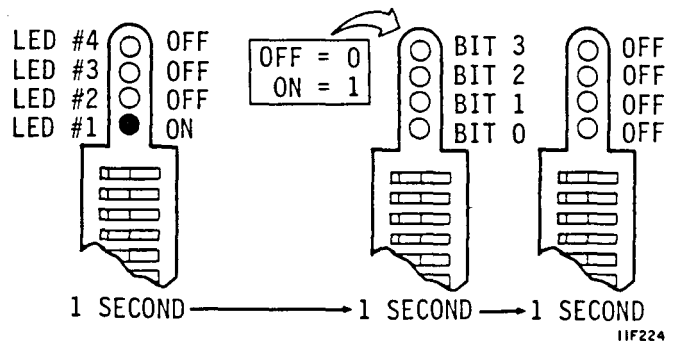

**Displaying the Second Four Bits of Failing Microcode Address**

LED #2 on and all others off means the next display shows the second four bits of failing microcode address for an unrecoverable system error. All LEDs remain off for one second before going to the next sequence.

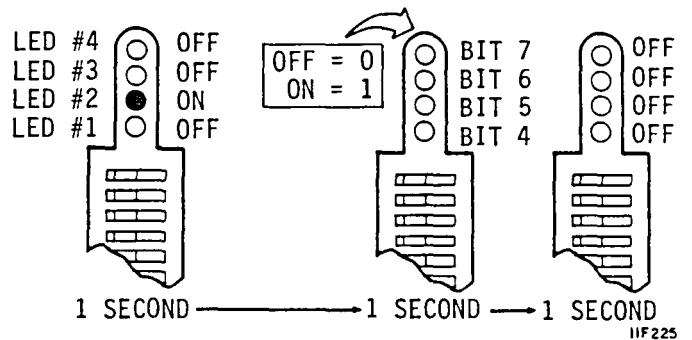

**Displaying the Third Four Bits of Failing Microcode Address**

LEDs #1 and #2 on and all others off means the next display shows the third four bits of failing microcode address for an unrecoverable system error. All LEDs remain off for one second before going to the next sequence.

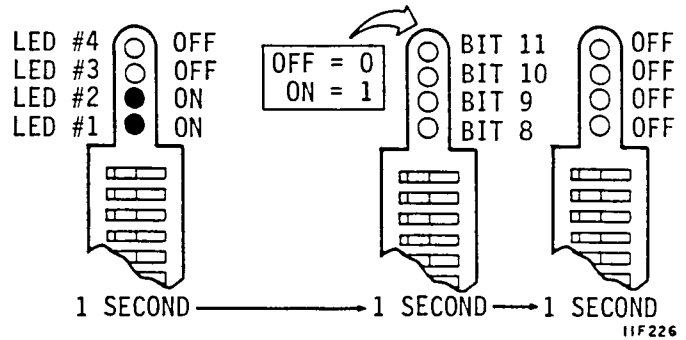

**Displaying the Last Four Bits of Failing Microcode Address**

LED #3 on and all others off means the next display shows the last four bits of the failing microcode address for an unrecoverable system error. All LEDs remain off for one second. The sequence will then repeat.

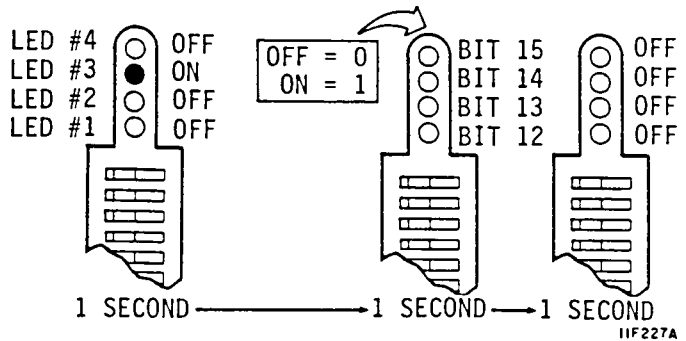

**Displaying Write/Read Test Failure**

LEDs 3 and 4 flash alternately with 1 and 2 to indicate a write/read test failure on the diagnostic cylinder.

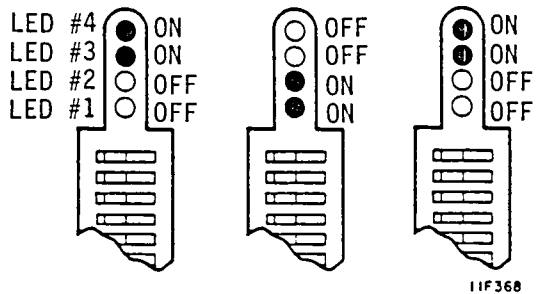

## Reading the I/O Board LEDs on High-Performance SCSI Drives

Some of the I/O board LED displays presented on high-performance SCSI drives are interpreted differently than those on standard SCSI drives. The meanings of the displays shown in the top half of table 2-13 are the same on all drives. The individual test failure displays and test completion display apply only to high-performance SCSI drives as indicated. The unrecoverable system error displays that can appear on standard SCSI drives do not appear on high-performance SCSI drives.

TABLE 2-13. I/O BOARD LEDES ON HIGH-PERFORMANCE SCSI DRIVES

LED				Meaning
4 Red	3 Red	2 Red	1 Grn	
Off	On	Off	F	No activity and drive is available. Flashing green is "heartbeat".
Off	Off	Off	F	Command is executing and unit is not available.
On	On	On	Off	Read or write retry is in progress.
F	F	F	F	CDIC failure.
On Off	On Off	Off On	Off On	Write/read test failure on diagnostic cylinder. LED 3 & 4 flash alternately with 1 & 2.
The following binary displays (codes) show test failure information for high-performance SCSI drives only. The corrective action for each code (except 15) is to replace the I/O board. Code 15 means the tests passed.				
Off	Off	Off	On	Microprocessor test
Off	Off	On	Off	Static RAM test
Off	Off	On	On	MAC register test
Off	On	Off	Off	Buffer controller test
Off	On	Off	On	Disk formatter test
Off	On	On	Off	Dynamic RAM test
Off	On	On	On	ESP Test
On	Off	Off	Off	CDIC Test
On	Off	Off	On	DMA to/from FIFO test
On	Off	On	Off	IBP test
On	Off	On	On	DRAM parity error test
On	On	On	On	Test Passed
F = LED is flashing.				

TESTING IPI INTERFACE DRIVES

The Self-Test and Initialization Sequence

The drive self-test and initialization sequence is shown on the flow chart below.

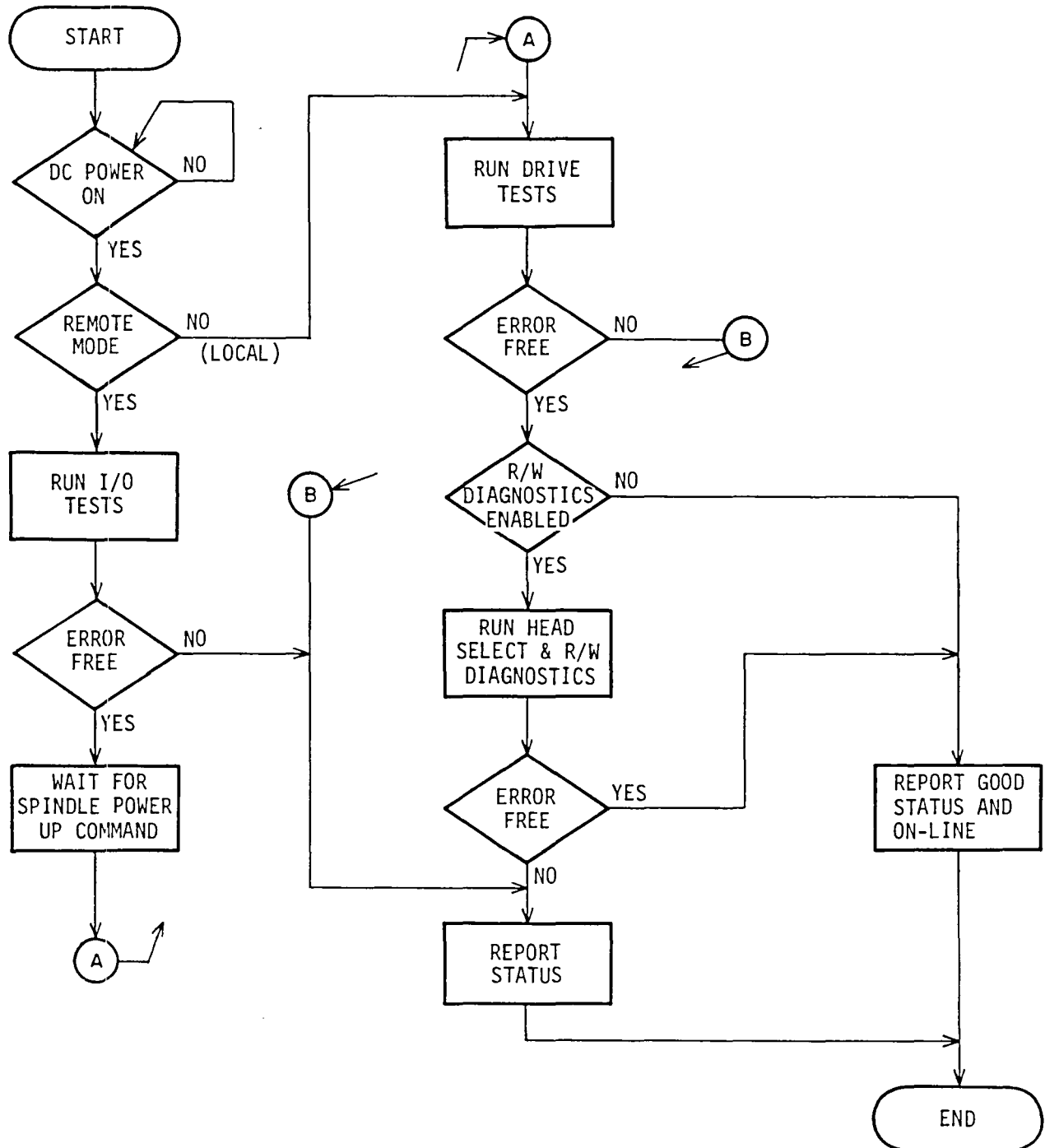

Starting the Tests

The I/O MPU and Control MPU self-test sequences start when dc power is applied or a Reset Drive Selective Reset is received (see the flowchart below).

The I/O and drive circuits are tested first. The I/O tests include checks of the serializer/deserializer (SERDES) and I/O circuits, and an I/O MPU self-test. The drive self-test checks the Control MPU. Testing stops and status is reported if an error is found.

The drive begins its start sequence if the I/O and drive self-tests run error-free. If these tests run error-free, the Control MPU in the drive runs a series of servo tests. The drive is capable of normal operation if these tests run error-free.

The controller can direct the running of write and read tests. The drive must be ready, not write protected, and there may be no faults present. If the drive is write protected, it will run only the read portion of the tests.

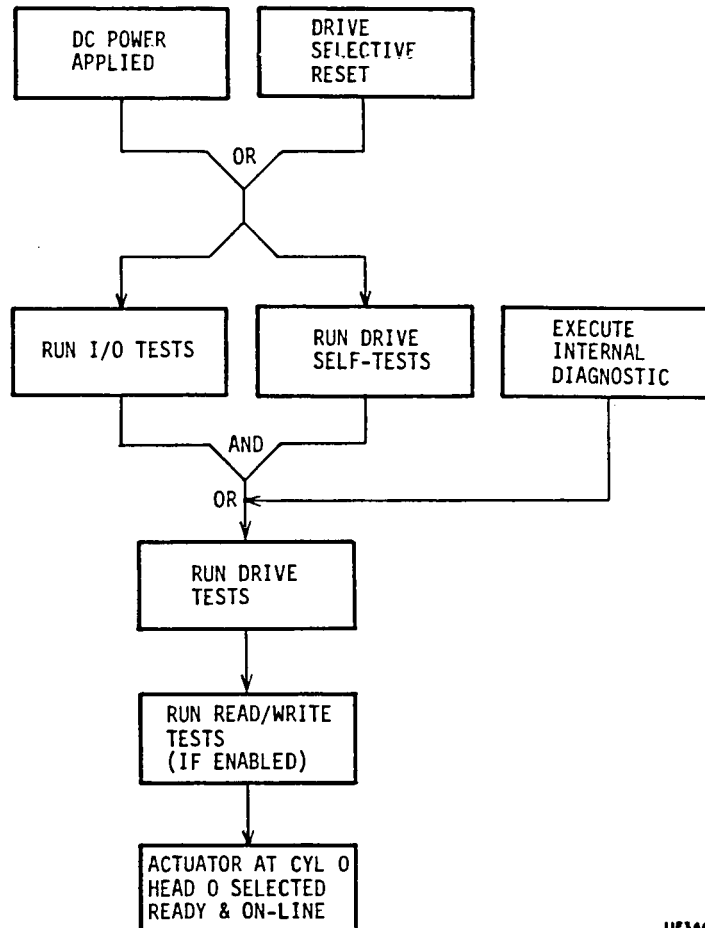

11P346A

If an error is detected in any test, testing stops and the appropriate error and status codes are reported. If all tests run error-free, the drive will be ready and the actuator will be at cylinder zero with head zero selected.

### Execute Internal Diagnostics Function

Receipt of this function runs an access test, a head select test, and a read/write test.

The access test performs the following operations:

- Return to zero seek operation
- Single track seek
- Servo recalibrate
- Maximum seek
- Random seek

Successful completion of this test allows starting of the Head Select test provided the Disable Write/Read Diagnostic bit is not set. The Head Select and Write/Read tests can be disabled by issuing the Disable Read/Write Diagnostics Function Code.

The Head Select test performs a seek to the diagnostic cylinder, waits for on-cylinder, and then sequentially selects all heads on the cylinder. Successful completion of this test allows starting of the Write/Read test.

The write and read tests run if the drive is Ready, is not write protected, and no fault conditions exist. If the drive is write protected, it will run only the access and read tests. The header is read and verified on the diagnostic cylinder. If no errors are found, data patterns are written on the diagnostic cylinder, after which they are read back and verified.

### Read Drive Specific Information (Bus Control 43)

The Read Drive Specific Information bus control transfers status information to the controller. This status information fits into two general categories:

- Native-controlled status -- generated by the Control MPU. Although the codes are numerically different, they report the information available via the status/control panel.
- Interface-controlled status -- generated by the I/O MPU.

The response to the bus control has the following parameters:

- Native-Controlled Diagnostic Status Codes -- presented in octets 02 - 11 and listed in table 2-14. Refer to table 2-6 earlier in this section for more complete status definitions.
- Native-Controlled Diagnostic FRU Codes -- presented in octets 12 - 15 and listed in table 2-15.
- Native-Controlled Diagnostic Fault Codes -- presented in octets 16 - 1D and listed in table 2-16.
- Interface-Controlled Diagnostic Status Codes -- presented in octets 1E - 1F and listed in table 2-17.
- Interface-Controlled Diagnostic FRU Codes -- presented in octets 20 - 21 and listed in table 2-18.
- Interface-Controlled Diagnostic Fault Codes -- presented in octets 22 - 23 and listed in table 2-19.

TABLE 2-14. NATIVE-CONTROLLED DIAGNOSTIC STATUS CODES

Status Code	Status Description
80	Ready & On Cylinder
82	Motor Stopping
83	Motor Stopped
84	First Load/Calibrate
85	Sequence Delay
86	START Switch Pressed & Waiting for Power Sequence Signals
87	Starting Motor
88	Motor Up to Speed
89	I/O Self-Test Passed
8A	Drive in Sweep Segment
8B	Heads Left on Last Cylinder of Sweep
C6	Seek Timeout
CB	Off Track Seek Error
CD	Illegal Cylinder Address
CF	Seek Error on Settle In
D4	First Seek Fault on Retract
D5	First Seek Fault on Load
D6	First Seek Fault on RTZ
D7	First Seek Fault on Calibrate
D8	Speed Loss
D9	Motor Can't Start Due to Error
DA	Emergency Retract
E0	Motor MPU Failure
E1	Servo MPU Failure
E2	I/O Status Transfer Failed
EE	I/O Self-Test Failed

TABLE 2-15. NATIVE-CONTROLLED DIAGNOSTIC FRU CODES

FRU Code	FRU Description
81	Control Board
82	Module
83	Power Supply
84	I/O Board
85	Control Board
86	Module

TABLE 2-16. NATIVE-CONTROLLED DIAGNOSTIC FAULT CODES

Fault Code	Fault Description
80	Good Status
81	Read • Write Fault
82	(Read + Write) • Off Cylinder Fault
84	First Seek Fault
88	Write Fault
90	Write • Write Protected Fault
A0	Head Select Fault
C0	Voltage Fault

TABLE 2-17. INTERFACE-CONTROLLED DIAGNOSTIC STATUS CODES

Status Code	Status Description
<u>Read/Write Tests</u>	
00	Good Status
01	Failed during seek to diagnostic cylinder
02	Failed during RTZ seek from diagnostic cylinder
03	Not defined
04	Not defined
05	Failed during head select test
06	Failed during read header test
07	Failed during write data test
08	Failed during read data test
09	Sync byte error during read header test
0A	Data error during read header test
0B	Sync byte error during read data test
0C	Data error during read data test
<u>Access Tests</u>	
13	Failed during servo test
14	Failed during random seek test
15	Failed during access RTZ test
<u>Read Drive Specific Tests</u>	
20	Failed during read up of diagnostic status/error code log test
21	Failed during read up of FRU log test
22	Failed during read up of display fault log test

TABLE 2-18. INTERFACE-CONTROLLED DIAGNOSTIC FRU CODES

FRU Code	FRU Description
01	Control Board
02	Module
03	Power Supply
04	I/O Board
05	Control Board
06	Module

TABLE 2-19. INTERFACE-CONTROLLED DIAGNOSTIC FAULT CODES

Fault Code	Fault Description
00	Good Status
01	Read • Write Fault
02	(Read + Write) • Off Cylinder Fault
04	First Seek Fault
08	Write Fault
10	Write • Write Protected Fault
20	Head Select Fault
40	Voltage Fault

**SECTION 3**

**REPAIR AND REPLACEMENT**



---

## CAUTION

When servicing the drive, observe all precautions listed under Electrostatic Discharge Protection in section 1 of this manual. Failure to observe these precautions can result in serious damage to electronic assemblies.

## INTRODUCTION

Repair of the drive is limited to replacement of defective parts and assemblies. This section describes removal and replacement of all major field replaceable parts and assemblies. The information here should be used in conjunction with that in the parts data manual.

The procedures in this section assume that the drive is mounted in the 2X drawer, and the drawer is mounted on slides in an equipment rack or cabinet. But unless otherwise specified, it is not necessary to remove the drive from the 2X drawer to perform maintenance.

All procedures require that power be removed from the drive and power supply. Prior to performing the maintenance, you should be thoroughly familiar with the operation of the drive, with all information in section 1, and with the safety information in the front of this manual.

Some procedural steps in this section apply only to drives with one of the available interfaces (SMD, SCSI, or IPI). The user's manual for your drive provides more detailed information about interface (I/O) cabling and accessories. That manual also discusses how to set the switches located on the circuit boards.

Each procedure is assigned a unique number. The numbers are used elsewhere in the manual to reference the procedures. The procedures and numbers are organized into three categories: 31XX - mechanical, 32XX - electromechanical, and 33XX - electronic (circuit boards).



- 3101 - Top Cover Removal & Replacement
- 3102 - Entire Drive Removal & Replacement
- 3103 - Front Panel Removal & Replacement
- 3201 - Fan Removal & Replacement
- 3202 - Operator Panel or Status/Control Panel Removal & Replacement
- 3203 - Power Supply Removal & Replacement
- 3204 - Module Removal & Replacement
- 3301 - I/O Board Removal & Replacement
- 3302 - Control Board Removal & Replacement
- 3303 - Voltage Converter Removal & Replacement

## 3101 - TOP COVER REMOVAL & REPLACEMENT

### REMOVAL

#### CAUTION

With the top cover removed, electrostatic sensitive components are exposed and may be seriously damaged by static electricity. To avoid possible damage, observe all precautions listed under Electrostatic Discharge Protection in section 1 of this manual.

Be careful not to damage the system cabling when sliding the drive in the drawer and the drawer in and out of the rack.

1. Remove front panel insert from each drive (see figure 3-1).

#### NOTE

The release latch on the left-hand drive locks the 2X drawer in the rack. The release latch on the right-hand drive has no function.

2. Push 2X drawer release latch to the right and extend 2X drawer to fully extended position.
3. Remove power from drive as follows:
  - For drives with operator panel or status/control panel:
    - a. Press START switch to stop the drive.
    - b. Wait for Ready indicator (in START switch) to stop flashing; then, set On/Standby switch on power supply to Standby position.
  - For drives without either panel, set On/Standby switch on power supply to Standby position.
4. Remove inner drawer locking screw. Push 2X drawer release latch to the right, lift inner drawer up, and slide it outward to gain access to top cover.
5. Remove screws securing top cover to drive.

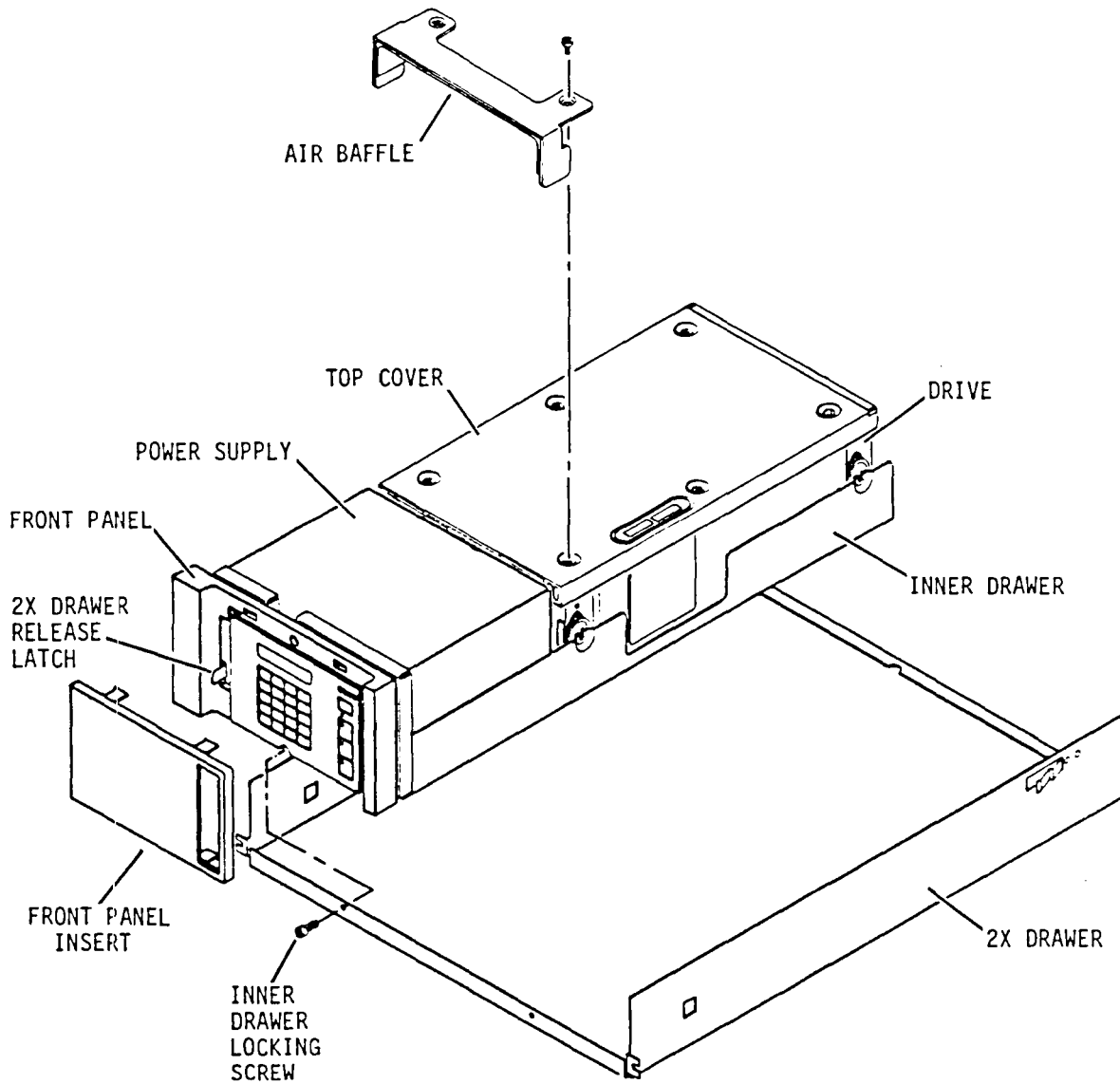

11H88D

Figure 3-1. Top Cover Removal and Replacement



**NOTE**

To maintain drive configuration whenever the top cover is removed, always identify which drive that the top cover was removed from.

6. Carefully lift off air baffle (if used) and cover.

**REPLACEMENT**

1. If new (replacement) top cover is being installed, copy drive information from labels of old top cover to new labels and attach new labels to new top cover.

**CAUTION**

When replacing cover, use care to avoid damaging logic boards.

2. Ensure power is removed from drive. Place top cover on drive. If air baffle is used, align it to screw holes in top cover. Secure cover with screws (see figure 3-1).
3. Push inner drawer back into 2X drawer, and secure into place with locking screw.
4. Set On/Standby switch on power supply to On (1) position.
5. Push 2X drawer back to closed position in rack.
6. Install front panel insert.

## 3102 - ENTIRE DRIVE REMOVAL & REPLACEMENT

The drive is mounted in the 2X drawer, and the drawer is mounted on slides in an equipment rack (see figure 3-2).

### REMOVAL

1. Remove front panel insert from each drive.

#### NOTE

The release latch on the left-hand drive locks the 2X drawer in the rack. The release latch on the right-hand drive has no function.

2. Push 2X drawer release latch to the right and extend 2X drawer to gain access to On/Standby switch on power supply.
3. Remove power from drive as follows:
  - For drives with operator panel or status/control panel:
    - a. Press START switch to stop the drive.
    - b. Wait for Ready indicator (in START switch) to stop flashing; then, set On/Standby switch on power supply to Standby position.
  - For drives without either panel, set On/Standby switch on power supply to Standby position.
4. Push 2X drawer back to closed position in rack.
5. For SMD interface drives, remove I/O cover and cable clamps from I/O cable bracket.

#### CAUTION

Remove terminators by hand. They could be damaged if a pliers or other tool is used.

6. Disconnect I/O cables, terminators, and system ground strap from drive.
7. For SMD interface drives, remove I/O cable bracket from drive rear panel.
8. For drives with synchronized spindles (an option for IPI interface drives with parallel read/write), disconnect the motor sync cable from J50 on the I/O board.

9. Disconnect ac power cable from site power.
10. Push 2X drawer release latch to the right and extend 2X drawer to fully extended position.
11. Remove inner drawer locking screw.
12. Push 2X drawer release latch to the right, lift inner drawer up and remove it from 2X drawer. Place inner drawer on work table.
13. Loosen shock mount screws securing module to inner drawer.
14. For drives with voltage converter, remove dc power cables from connectors CN9 and CN10 located side-by-side above the I/O connectors; skip to step 18.
15. If air baffle is used, remove (2) screws securing air baffle to drive. Set aside air baffle and screws.
16. Disconnect dc ground strap from module.
17. Lift front end of drive up and disconnect dc power cable from J15(A) on control board.
18. For drives with operator panel or status/control panel, perform the following:
  - a. Disconnect jumper cable from J13 on control board (see figure 3-2).
  - b. Remove cable clamp from side of module.
19. Carefully lift drive out of drawer and move to desired location.

## REPLACEMENT

1. Loosely attach drive shock mount screws to drive shock mounts.
2. Mount drive to inner drawer so that drive is supported on shock mount screws. If a ground strap is used on screw, ensure it is positioned between screw head and inner drawer.
3. For drives with voltage converter, plug dc power cables into connectors CN9 and CN10 located side-by-side above the I/O connectors; skip to step 7.



4. Lift front end of drive up and connect dc power cable to J15(A) on control board.
5. Attach dc ground strap to module.
6. If air baffle is used, attach air baffle above drive top cover with (2) screws.
7. For drives with operator panel or status/control panel, perform the following:
  - a. Connect jumper cable to J13 on control board.
  - b. Attach cable clamp to side of module as shown in figure 3-2.
8. Tighten shock mount screws to secure drive in place.
9. Place inner drawer in 2X drawer and secure with locking screw.
10. Push 2X drawer back to closed position in rack.
11. For SMD interface drives, attach I/O cable bracket to drive rear panel.
12. Connect I/O cables and terminators to drive connectors.
13. For SMD interface drives, attach strain relief clamp, I/O cable cover, and grounding clamp to cable bracket. Some drives use one clamp (installed with arrow pointing up).
14. For drives with synchronized spindles, connect the motor sync cable to J50 on the I/O board.
15. Connect system ground strap to drive rear panel.
16. Connect ac power cord to site power.
17. Push 2X drawer release latch to the right and extend 2X drawer to gain access to On/Standby switch on power supply.
18. Set On/Standby switch on power supply to On (1) position.
19. Push 2X drawer back to closed position in rack.
20. Install front panel insert.

## 3103 - FRONT PANEL REMOVAL & REPLACEMENT

The front panel attaches to the inner drawer. The following procedure provides instructions for removing and replacing the front panel.

### REMOVAL

1. Remove front panel insert from each drive (see figure 3-3).

#### NOTE

The release latch on the left-hand drive locks the 2X drawer in the rack. The release latch on the right-hand drive has no function.

2. Push 2X drawer release latch to the right and extend 2X drawer to gain access to On/Standby switch on power supply.
3. Remove power from drive as follows:
  - For drives with operator panel or status/control panel:
    - a. Press START switch to stop the drive.
    - b. Wait for Ready indicator (in START switch) to stop flashing; then, set On/Standby switch on power supply to Standby position.
  - For drives without either panel, set On/Standby switch on power supply to Standby position.
4. Remove front panel as follows:
  - For drives with status/control panel:
    - a. Remove the two screws (left side of front panel) securing status/control panel to front panel.
    - b. Disconnect jumper cable from P13 while removing status/control panel from front panel.
    - c. Remove filter from front panel.
    - d. Remove the two screws (right side of front panel) securing front panel to inner drawer and remove front panel from drawer.

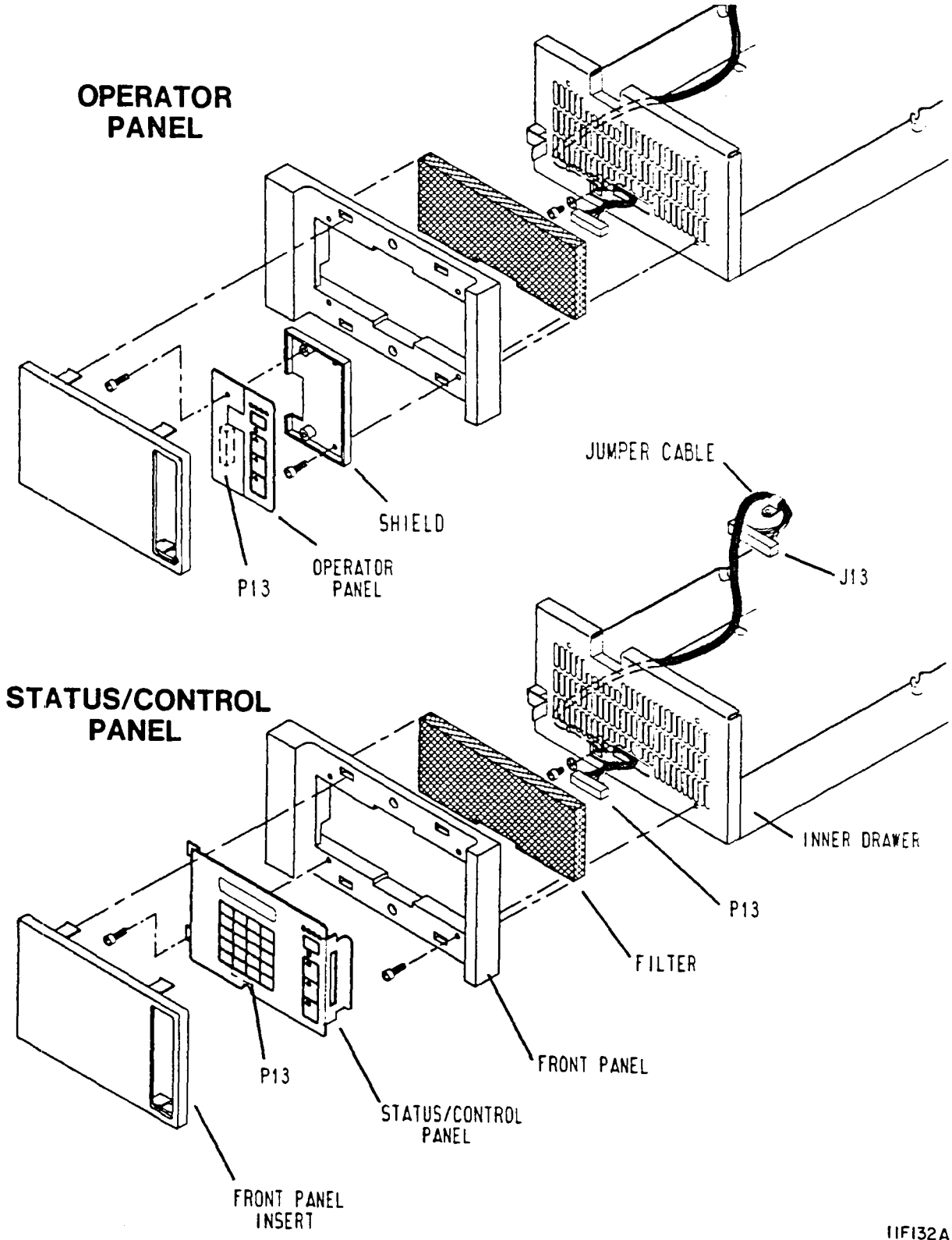

IIF132A

Figure 3-3. Front Panel Removal & Replacement

- For drives with operator panel:
  - a. Remove screws securing operator panel to shield and remove operator panel.
  - b. Disconnect jumper cable from P13 on operator panel.
  - c. Remove screws securing shield to front panel and remove shield.
  - d. Remove filter from front panel.
  - e. Remove the two screws (left side of front panel) securing front panel to inner drawer and remove front panel from drawer.
- For drives without either panel:
  - a. Remove filter from front panel.
  - b. Remove screws securing front panel to inner drawer and remove front panel from drawer.

## REPLACEMENT

### NOTE

When installing the front panel, ensure that the overhang covers the rack frame (vertical support). If left and right hand inner drawers are interchanged in the 2X drawer, rotate the front panels 180 degrees.

1. Install front panel as follows (see figure 3-3):
  - For drives with status/control panel:
    - a. Align front panel to inner drawer so that holes in front panel are centered on holes in inner drawer.
    - b. Secure front panel into place with the two screws on right side of front panel.
    - c. Place filter in front panel.
    - d. Connect jumper cable to P13 while attaching status/control panel to front panel and secure with screws.
    - e. Install front panel insert.

- For drives with operator panel:
    - a. Align front panel to inner drawer so that holes in front panel are centered on holes in inner drawer.
    - b. Secure front panel into place with the two screws on left side of front panel.
    - c. Place filter in front panel.
    - d. Align shield to front panel and secure with screws.
    - e. Connect jumper cable to P13 while attaching operator panel to shield and secure with screws.
    - f. Install front panel insert.
  - For drives without either panel:
    - a. Align top edge of front panel to top edge of inner drawer.
    - b. Secure front panel into place with screws.
    - c. Place filter in front panel.
    - d. Install front panel insert.
2. Set On/Standby switch on power supply to On (1) position.
  3. Push 2X drawer back to closed position in rack.

## 3201 - FAN REMOVAL & REPLACEMENT

This procedure describes how to replace a fan mounted on a standard fan bracket. To replace a fan mounted over a voltage converter, refer to procedure 3303 -- Voltage Converter Removal & Replacement.

### REMOVAL

1. Remove power from drive as follows:
  - For drives with operator panel or status/control panel:
    - a. Press START switch to stop the drive.
    - b. Wait for Ready indicator (in START switch) to stop flashing; then, set On/Standby switch on power supply to Standby position.
  - For drives without either panel, set On/Standby switch on power supply to Standby position.
2. Place inner drawer back into 2X drawer and push 2X drawer back to closed position in rack.
3. Disconnect ac power cable from site power source.
4. Disconnect P15 (fan connector) from J15(B) (pins 14 and 15) on control board (see figure 3-4).
5. Note direction of arrow (indicating air flow) on side of fan. For most installations, fan blows cooling air through the drive (preferred method). Other installations require reversed air flow.
6. Remove screws securing fan to bracket and remove fan from drive. Retain fan guard for use with replacement fan.

### REPLACEMENT

1. Orient fan and fan guard on bracket, ensuring that arrow on new fan points in same direction as arrow on old fan. Secure parts with screws, as shown in figure 3-4.
2. Connect P15 (fan connector) to J15(B) (pins 14 and 15) on control board.
3. Connect ac power cord to site power.
4. Reapply power to drive and observe fan operation.

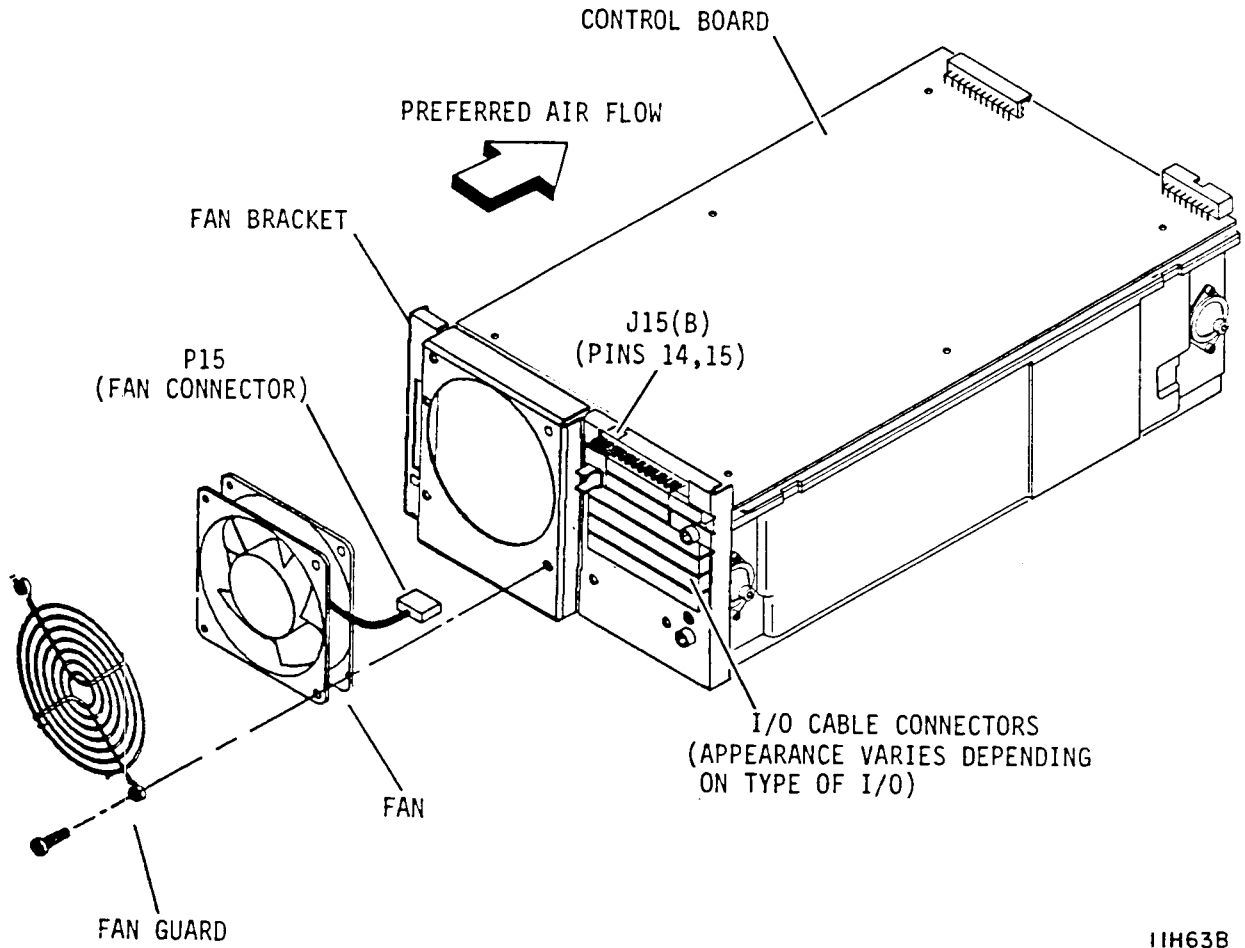

11H63B

Figure 3-4. Fan Removal and Replacement

## 3202 - OPERATOR PANEL AND STATUS/CONTROL PANEL REMOVAL & REPLACEMENT

The mounting location for either the operator panel or the status/control panel is behind the front panel insert. The panels have no replaceable parts but must be replaced as assemblies.

### REMOVAL

1. Remove front panel insert from each drive (see figure 3-5).

#### NOTE

The release latch on the left-hand drive locks the 2X drawer in the rack. The release latch on the right-hand drive has no function.

2. Push 2X drawer release latch to the right and extend 2X drawer to gain access to On/Standby switch on power supply.
3. Remove power from drive as follows:
  - a. Press START switch to stop the drive.
  - b. Wait for Ready indicator (on START switch) to stop flashing; then, set On/Standby switch on power supply to Standby position.
4. Complete the removal procedure as follows:
  - For drives with status/control panel:
    - a. Remove screws securing status/control panel to front panel.
    - b. Disconnect jumper cable from P13 while removing status/control panel from front panel.
  - For drives with operator panel:
    - a. Remove screws securing operator panel to shield and remove operator panel.
    - b. Disconnect jumper cable from P13 on operator panel.
    - c. Remove screws securing shield to front panel and remove shield.

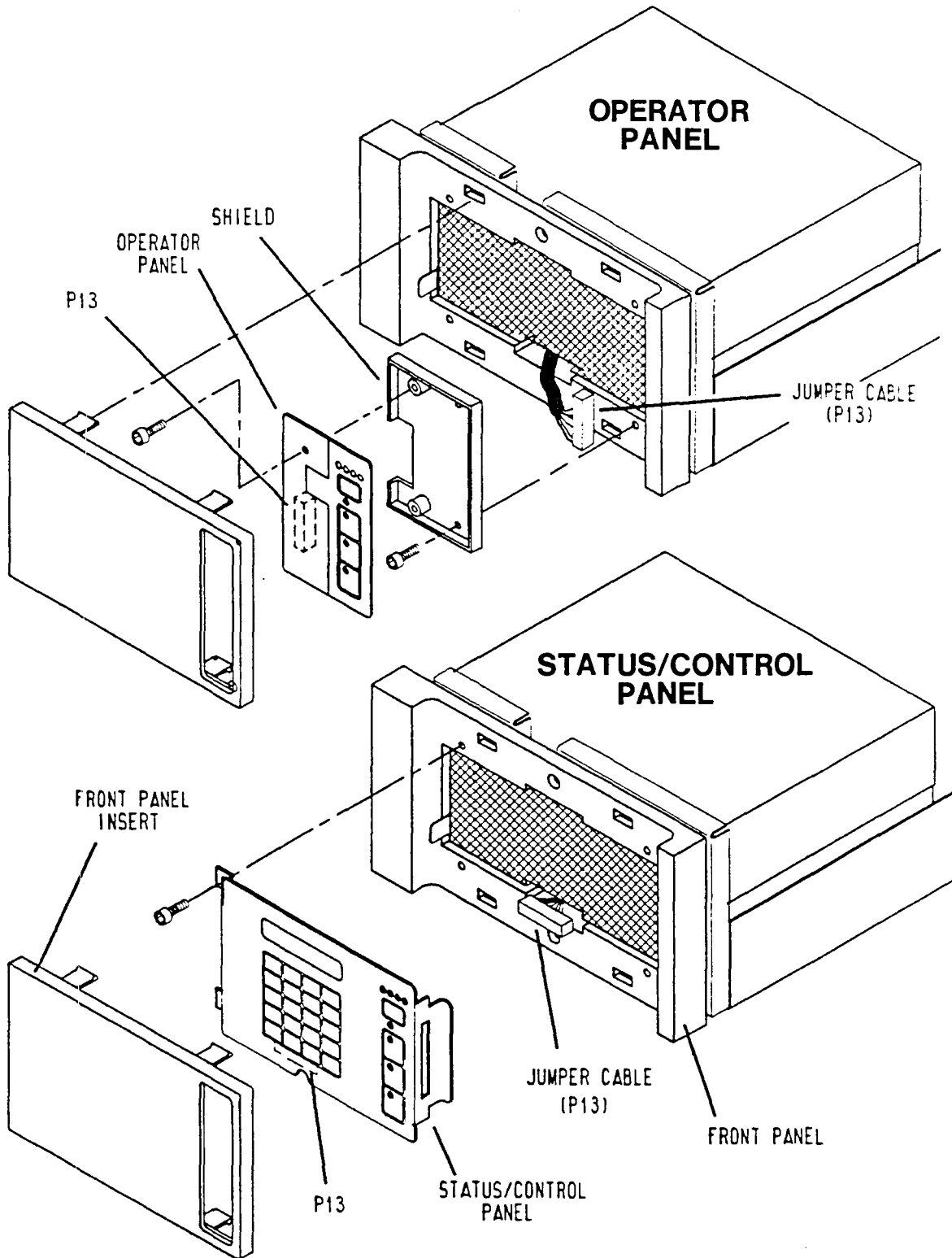

11F133A

Figure 3-5. Operator Panel or Status/Control Panel Replacement



## REPLACEMENT

1. Replace the panel as follows:
  - For drives with status/control panel:
    - a. Connect jumper cable to P13 on status/control panel.
    - b. Align status/control panel to front panel and secure with screws.
    - c. Remove protective film from front surface of status/control panel.
  - For drives with operator panel:
    - a. Remove screws attaching operator panel to shield.
    - b. Align shield to front panel and secure with screws.
    - c. Connect jumper cable to P13 on operator panel.
    - d. Align operator panel to shield and secure with screws.
2. Set On/Standby switch on power supply to On (1) position.
3. Push 2X drawer to closed position in rack.
4. Install front panel insert.

## 3203 - POWER SUPPLY REMOVAL & REPLACEMENT

The following procedure provides instructions for removing and replacing the power supply when it is mounted in line with the drive (see figure 3-6).

### REMOVAL

1. Perform entire drive removal procedure (3102).
2. Disconnect ac power cable from ac input connector J1.
3. Disconnect dc ground strap from power supply.
4. Disconnect dc power cable from J15 on power supply.
5. Remove screws securing power supply to inner drawer.
6. Lift power supply from inner drawer and move to desired location.

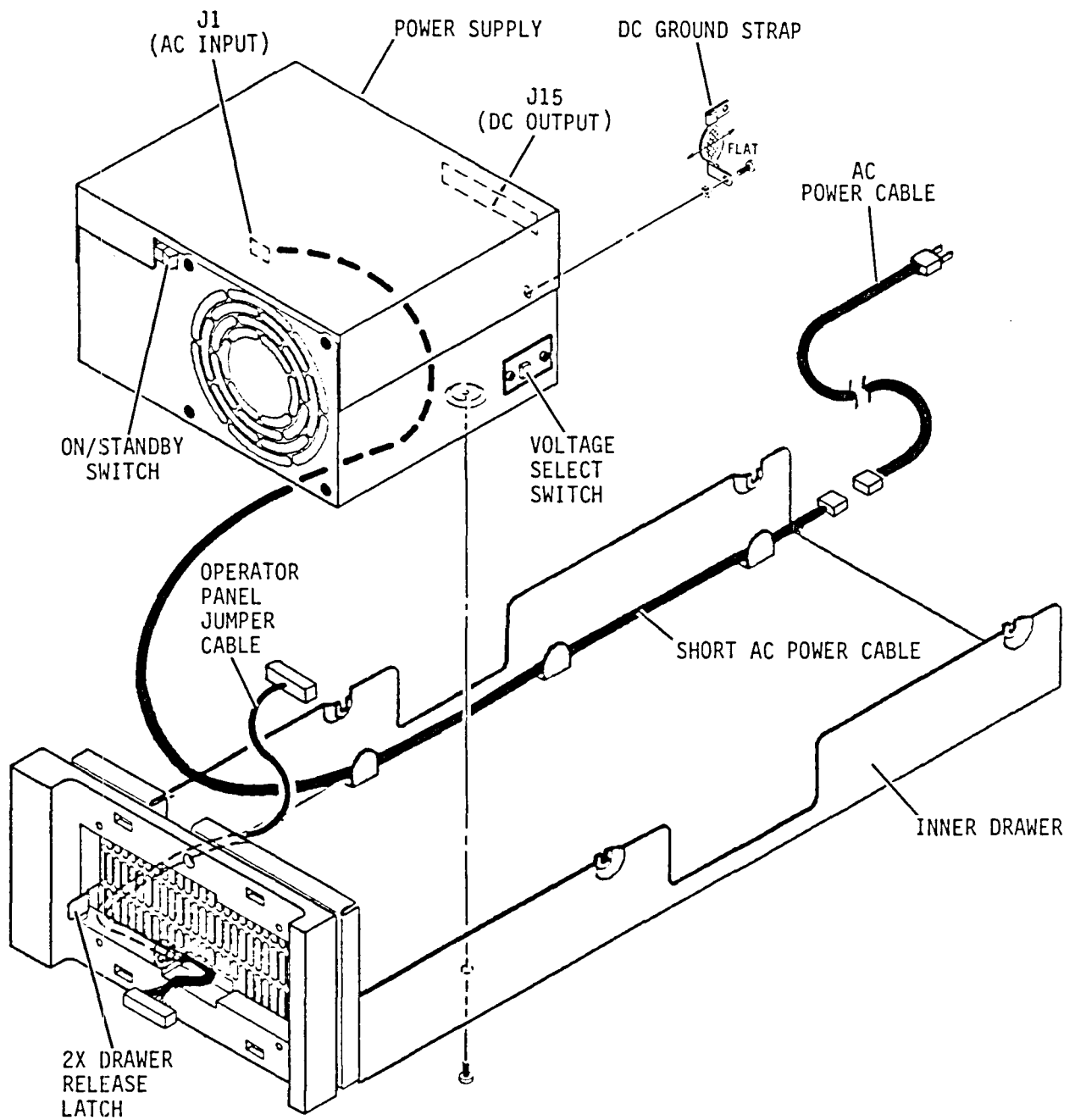

11H159

Figure 3-6. Power Supply Removal & Replacement

REPLACEMENT

CAUTION

Power supply will fail if voltage select switch is set for low range and a voltage in the high range is applied.

1. Ensure that voltage select switch is set to desired voltage range (see figure 3-7). If it is not, perform the following:
  - a. Remove screw securing voltage select plate to power supply and remove plate from power supply. Retain plate and hardware.
  - b. Set voltage select switch to desired range.
  - c. Reverse voltage select plate and install plate on power supply to lock switch in place.
2. Place power supply in inner drawer, and secure power supply to inner drawer with screws.

NOTES:

1 LOCKS VOLTAGE SWITCH IN EITHER 115V POSITION OR 230V POSITION (OTHER SIDE)

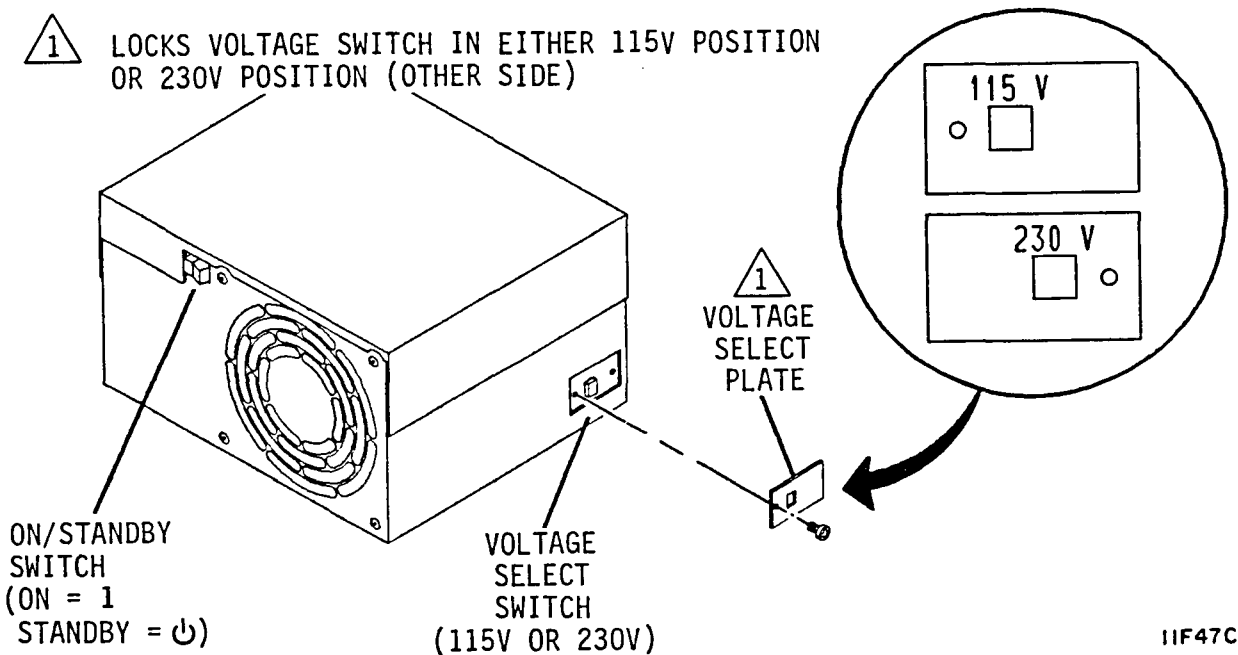

Figure 3-7. Power Supply Voltage Conversion

3. Connect dc power cable to J15 on power supply (see figure 3-6).
4. Orient dc ground strap as shown in figure 3-6, and connect dc ground strap to ac ground terminal on power supply. Ensure that lock washer is placed between ground strap and power supply case.
5. Connect ac power cable to ac input connector J1.
6. Perform entire drive replacement procedure (3102).

## 3204 - MODULE REMOVAL & REPLACEMENT

A temperature stabilization period of 4 or more hours may be required for the replacement module to reach the ambient temperature of the drive environment. Follow the instructions provided with the module regarding temperature stabilization.

### REMOVAL

1. Perform entire drive removal procedure (3102), except for removing I/O cable bracket from rear panel.
2. Perform control board removal procedure (3302).

By performing procedures 3102 and 3302, you have removed the drive from its mounting and removed all drive assemblies that were attached to the module.

### REPLACEMENT

1. Perform control board replacement procedure (3302).
2. Perform entire drive replacement procedure (3102).

## 3301 - I/O BOARD REMOVAL & REPLACEMENT

### REMOVAL

1. Perform top cover removal procedure (3101).
2. Place inner drawer back into 2X drawer and push 2X drawer back to closed position in rack.
3. For SMD interface drives, remove I/O cover and cable clamps from I/O cable bracket (one cable clamp on some drives).

### CAUTION

Remove terminators by hand. They could be damaged if a pliers or other tool is used.

4. Disconnect I/O cables and terminators from drive.
5. For IPI and SCSI interface drives that have these parts, remove I/O adapter board cover and remove I/O adapter board from connectors J06 and J07 (SCSI) or J3-1 and J3-2 (IPI) on I/O board.
6. For drives with synchronized spindles (an option for IPI interface drives with parallel read/write), disconnect the motor sync cable from J50 on the I/O board.
7. For drives with voltage converter:
  - a. Remove dc power cables from connectors CN9 and CN10 located side-by-side above the I/O connectors.
  - b. Loosen two screws securing connector adapter board (on which CN9 and CN10 are mounted) to fan bracket. Skip to step 9.
8. For drives with fan on rear panel, disconnect P15 (fan connector) from J15(B) (pins 14 and 15) on control board.
9. Remove screws securing rear panel and I/O board to drive (see figure 3-8).
10. Remove rear panel from drive. Retain panel and hardware.
11. Remove I/O board by disconnecting J20 from P20 on control board.

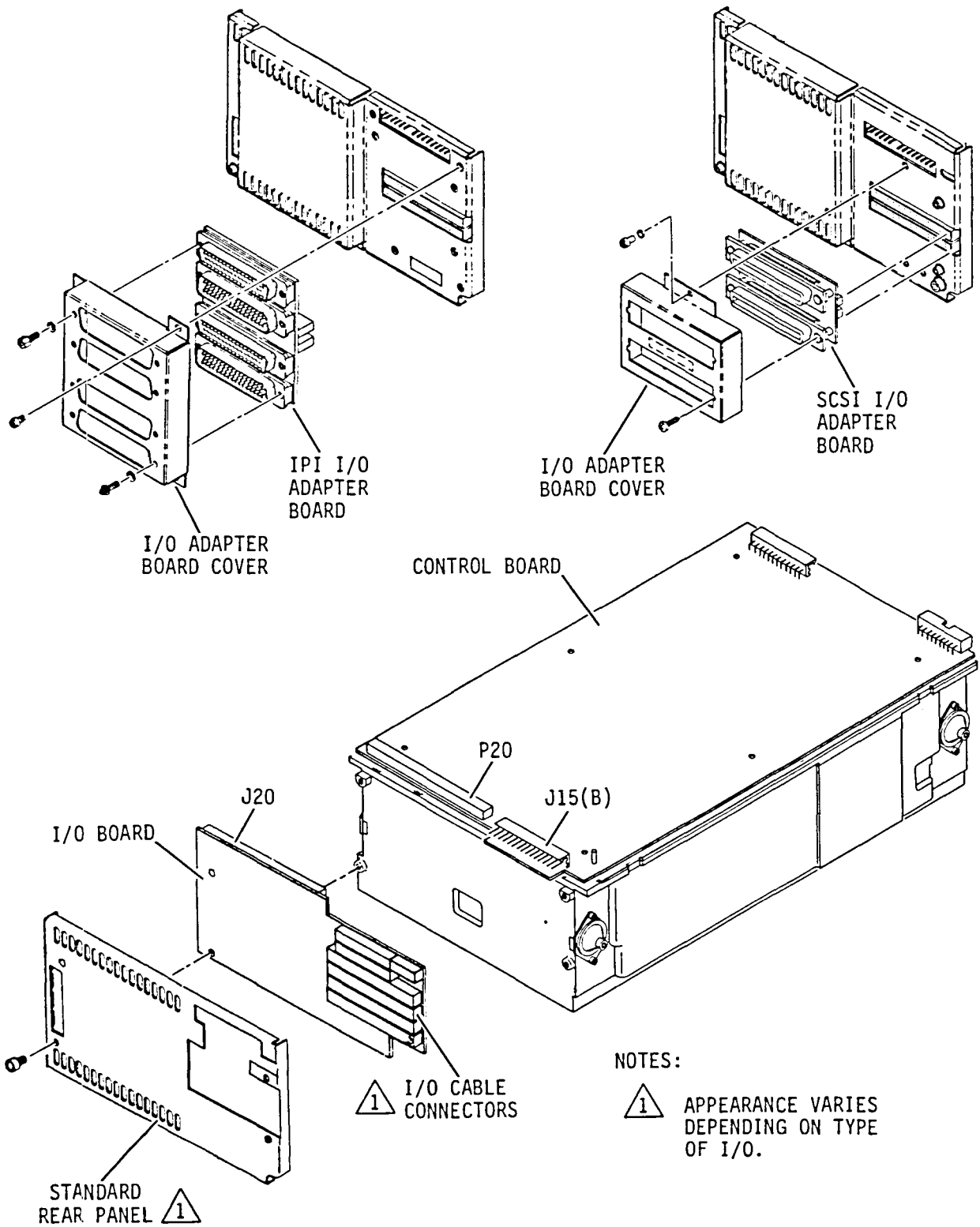

11H65D

Figure 3-8. Typical I/O Board Removal and Replacement



## REPLACEMENT

1. Ensure that all circuit board switches are set either to match removed board or as indicated in the installation section of the user's manual.
2. For drives with synchronous spindles, connect or disconnect the Enable Master Sync jumper to match removed board or as indicated in the installation section of the user's manual.
3. Align J20 on I/O board to P20 on control board and push the two connectors together (see figure 3-8).
4. For drives with voltage converter:
  - a. Align connector on rear of connector adapter board to J15(B) on control board and push the two connectors together to place fan bracket over I/O board.
  - b. Secure fan bracket with screws.
  - c. Tighten two screws securing connector adapter board to fan bracket.
  - d. Connect dc power cables to connectors CN9 and CN10 on connector adapter board. Skip to step 9.
5. Align rear panel to I/O board and secure rear panel with screws.
6. For drives with fan on rear panel, connect P15 (fan connector) to J15(B) (pins 14 and 15) on control board.
7. For IPI and SCSI interface drives that have these parts, attach I/O adapter board to connectors J06 and J07 (SCSI) or J3-1 and J3-2 (IPI) on I/O board. Attach I/O adapter board cover to rear panel.
8. For drives with synchronized spindles, connect the motor sync cable to J50 on the I/O board.
9. Connect I/O cables and terminators to drive connectors. Connect terminators to J06 on drives with SCSI interface, or to J3-1 and J3-2 on drives with IPI interface.
10. For SMD interface drives, attach cable clamps and I/O cable cover to I/O cable bracket. Some drives used one clamp (installed with arrow pointing up).
11. Perform top cover replacement procedure (3101).

## 3302 - CONTROL BOARD REMOVAL & REPLACEMENT

### REMOVAL

1. Perform I/O board removal procedure (3301).
2. Disconnect J13 from J13, and P15 from J15(A) (or J15(B) if power supply is mounted in a remote location) on control board (see figure 3-9).
3. Remove hex standoffs securing control board to module.

### CAUTION

Pins on P24 and P28 on control board are not protected in a connector. Be careful not to bend pins after control board is removed from module or they will not align properly when attaching board to module.

4. Disconnect P24 from J24 and P28 from J28, by carefully lifting up on board to remove it from module.

### REPLACEMENT

### CAUTION

Ensure that there are no bent pins on P24 and P28 on control board prior to attaching board to module.

1. Ensure that all circuit board switches are set either to match removed board or as indicated in the installation section of the user's manual.
2. Place control board on module guide pins (see figure 3-9).
3. Align P24 to J24 and P28 to J28 and push down to connect board to module.
4. Secure control board to module with hex standoffs.
5. Connect P13 to J13, and P15 to J15(A) (or J15(B) if power supply is mounted in a remote location) on control board.
6. Perform I/O board replacement procedure (3301).

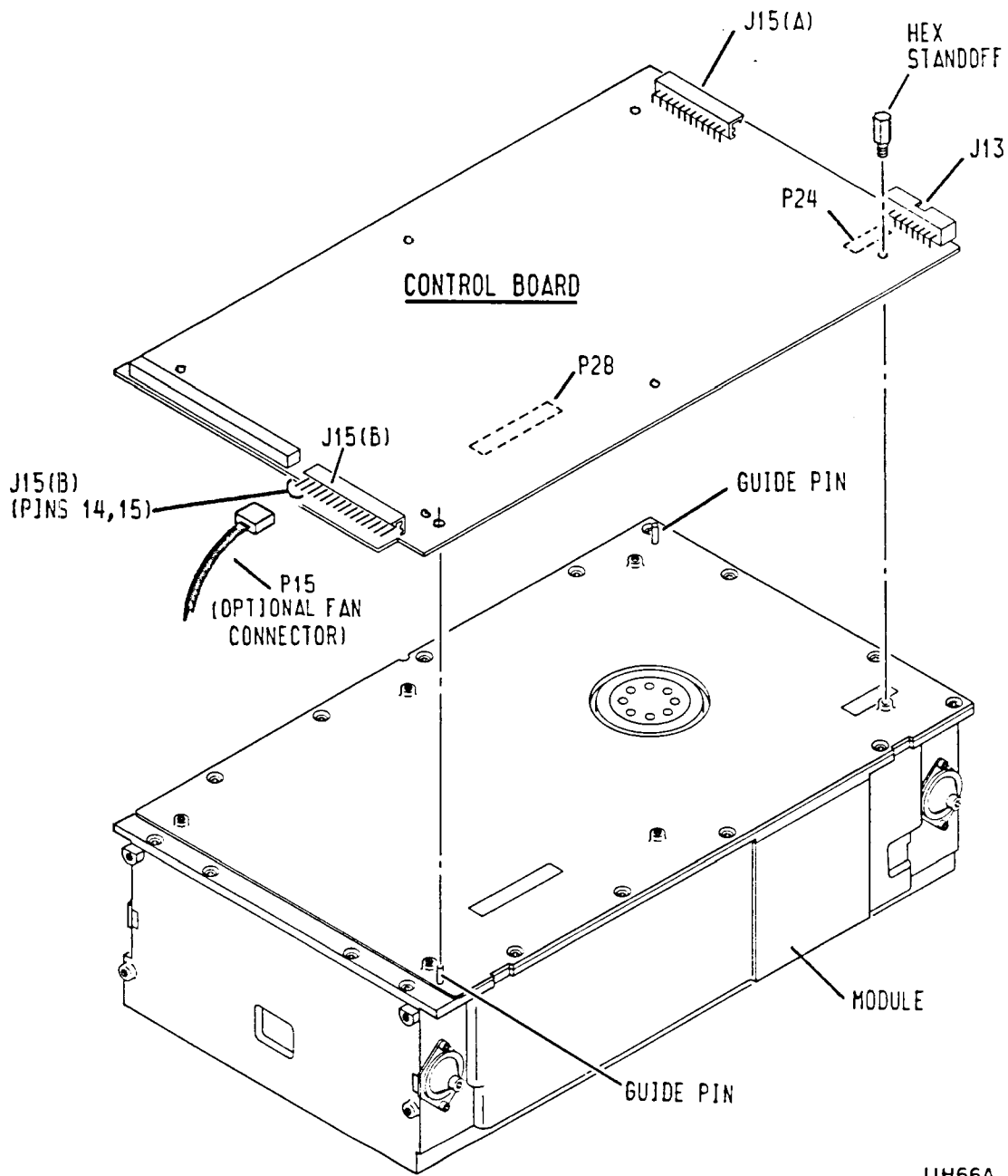

Figure 3-9. Control Board Removal & Replacement

## 3303 - VOLTAGE CONVERTER REMOVAL & REPLACEMENT

This procedure describes removal and replacement of the components making up the voltage converter. These include a voltage converter assembly attached behind the cooling fan, the cooling fan, and a connector adapter board attached to the rear cover.

### REMOVAL

1. Remove I/O cover and cable clamps from I/O cable bracket (one cable clamp on some drives).

### CAUTION

Remove terminators by hand. They could be damaged if a pliers or other tool is used.

2. Disconnect I/O cables and terminators from drive.
3. Remove dc power cables from connectors CN9 and CN10 located side-by-side above the I/O connectors.
4. Loosen two screws securing connector adapter board to fan bracket as shown in figure 3-10.
5. Remove screws securing fan bracket and I/O board to drive (refer to figure 3-8 earlier in the section).
6. Remove fan bracket from drive. Retain attaching hardware.
7. Disconnect P16 from J16 on connector adapter board (see figure 3-10).
8. Disconnect fan cable from connector adapter board.
9. To remove voltage converter assembly and fan, remove four screws securing these parts to fan bracket.
10. To remove connector adapter board, remove two screws securing board to fan bracket, and slide board away from bracket.

### REPLACEMENT

1. If connector adapter board was removed, slide board into position on fan bracket, and loosely install two screws that attach board to fan bracket.

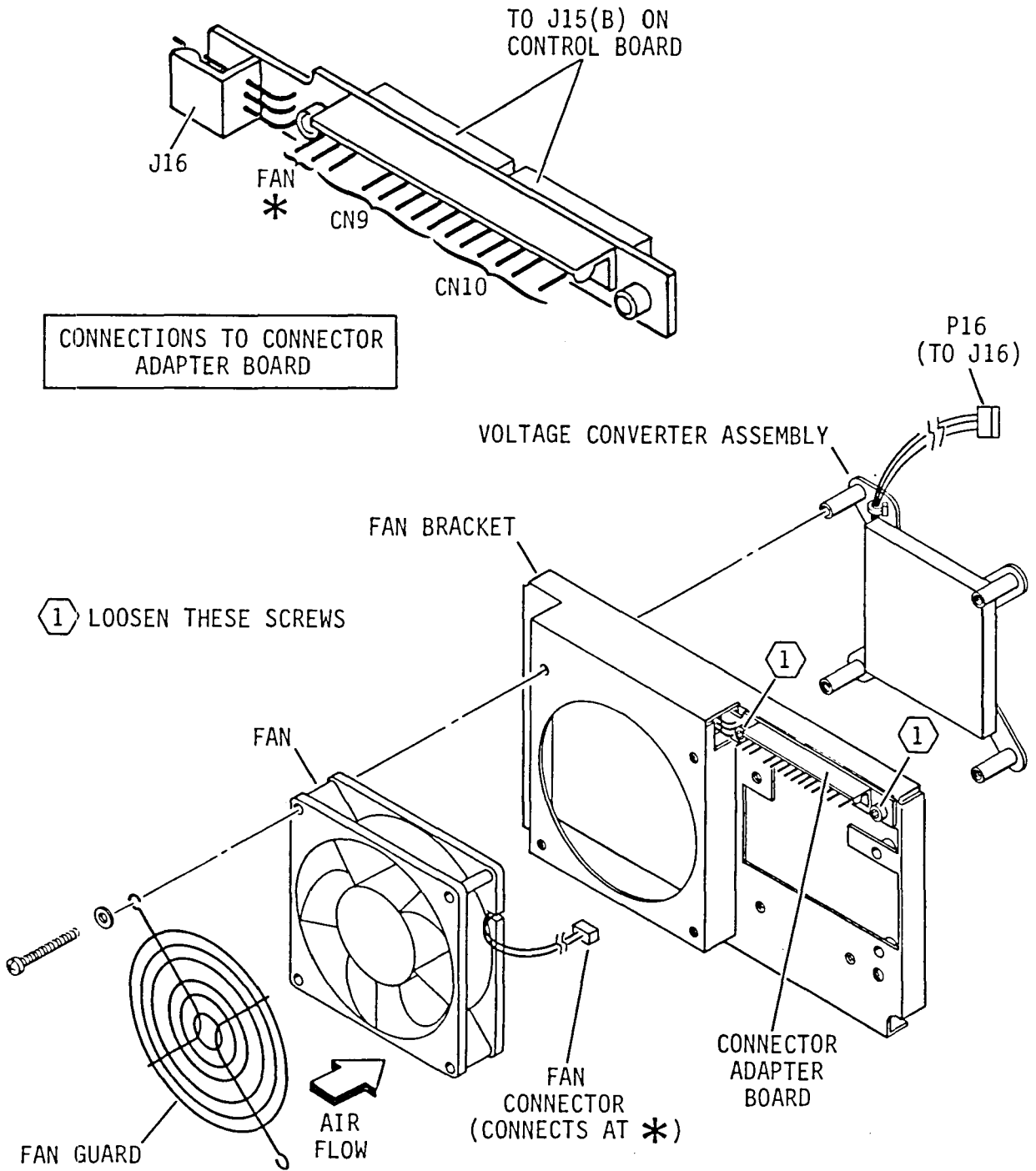

11H67A

Figure 3-10. Voltage Converter Removal & Replacement

2. If voltage converter assembly and fan were removed, perform the following steps:
  - a. Orient fan and fan guard on fan bracket, ensuring that arrow on fan points inward as shown in figure 3-10.
  - b. Place voltage converter assembly on opposite side of fan bracket, and align it with fan.
  - c. Secure parts with attaching hardware.
3. Connect fan cable to fan connection on connector adapter board (two pins to left of connector CN9).
4. Connect P16 to J16 on connector adapter board (see figure 3-10).
5. Align connector on rear of connector adapter board to J15(B) on control board and push the two connectors together to place fan bracket over I/O board. Secure fan bracket with screws.
6. Tighten two screws securing connector adapter board to fan bracket.
7. Connect dc power cables to connectors CN9 and CN10 on connector adapter board.
8. Connect I/O cables and terminators to drive connectors.
9. Attach cable clamps and I/O cable cover to I/O cable bracket. Some drives used one clamp (installed with arrow pointing up).

# COMMENT SHEET

**Manual Title:** \_\_\_\_\_

**Publication No:** \_\_\_\_\_

**Revision:** \_\_\_\_\_

**Name:** \_\_\_\_\_

**Company:** \_\_\_\_\_

**Street Address:** \_\_\_\_\_

**City:** \_\_\_\_\_ **State:** \_\_\_\_\_ **Zip Code:** \_\_\_\_\_

*This form is not intended to be used as an order blank. Seagate welcomes your evaluation of this manual. Please indicate any errors, suggested additions or deletions, or general comments below (please include page number references)*

*Please reply*

*No reply necessary*

Cut along line

Printed in U.S.A.

KBR 0502F

**No postage stamp necessary if mailed in U.S.A.**

*Fold on dotted lines and tape. Postal regulations prohibit the use of staples.*

FOLD

FOLD

FIRST CLASS  
PERMIT NO. 8241  
MINNEAPOLIS, MINN.

**BUSINESS REPLY MAIL**

NO POSTAGE STAMP NECESSARY IF MAILED IN U. S. A.

POSTAGE WILL BE PAID BY  
**SEAGATE TECHNOLOGY, INC.**  
**TECHNICAL PUBLICATIONS DEPARTMENT**  
**12701 WHITEWATER DRIVE**  
**MINNETONKA, MN. 55343**



CUT ALONG LINE

FOLD

FOLD





*Seagate Technology, Inc.*

*920 Disc Drive, Scotts Valley, California 95066-4544, USA*

**Publication Number: 83325720-F**

---